

BY-LAW NO. 186-06

OF

THE CORPORATION OF THE CITY OF CAMBRIDGE

Being a by-law of the Corporation of the City of Cambridge to amend By-law No. 62, as amended, being a by-law with respect to parking. (PRIVATE PROPERTY)

WHEREAS the *Municipal Act, 2001*, S.O. 2001, C. 25, S. 11(2) TABLE, Paragraph 10, and S. 100 and S. 101 authorizes the passing of by-laws with respect to parking;

AND WHEREAS the Council of the Corporation of the City of Cambridge enacted By-law No. 62 on the 7th day of November, 1988, and has enacted amendments thereto;

AND WHEREAS it is deemed expedient to amend By-law No. 62;

NOW THEREFORE THE MUNICIPAL COUNCIL OF THE CORPORATION OF THE CITY OF CAMBRIDGE ENACTS AS FOLLOWS:-

- 1. By-law No. 62 of The Corporation of the City of Cambridge, as amended, is hereby amended by deleting everything after the words " By-law 62 of The Corporation of The City of Cambridge" and substituting in it's place the following:

PART I – DEFINITIONS

- 1. The definitions contained in the *Highway Traffic Act*, R. S. O. 1990, c. H. 8, as amended, shall apply in the interpretation of this By-law except where such definitions are inconsistent with this By-law, in which case the definitions herein apply.

In this by-law:

- 1. **"Authorized Sign"** means any sign placed or erected under the authority of this By-law and the authority of the Commissioner of Transportation and Public Works or his/her designate, for the purpose of regulating parking.
- 2. **"City"** means The Corporation of the City of Cambridge;
- 3. **"Commercial Motor Vehicle"** means a motor vehicle having permanently attached thereto a truck or delivery body and includes ambulances, hearses, fire apparatus, buses, and tractors used for hauling purposes on the highways.
- 4. **"Commissioner of Transportation and Public Works"** means the person appointed to that position by the City;
- 5. **"Enforcing Authority"** means either of the Waterloo Regional Police Service or the City;

6. **"Enforcing Official"** means:
- i. a police officer;
 - ii. a police cadet;
 - iii. a civilian person engaged by the Waterloo Regional Police Service;
 - iv. a by-law enforcement officer;
 - v. a Provincial Offences Officer;
 - vi. a municipal law enforcement officer engaged by the City to enforce the provisions of this by-law or any parts thereof;
 - vii. with respect to identified properties, as identified in **Schedule "A"** to this By-law, a municipal law enforcement officer whose name appears in **Schedule "A"** of this By-law; or,
 - viii. any person or class of persons designated pursuant to the *Provincial Offences Act*.
7. **"Motor Vehicle"** includes an automobile, motorcycle, motor assisted bicycle and any other vehicle propelled or driven otherwise than by muscular power, but does not include a street car, or other motor vehicles running only upon rails, or a motorized snow vehicle, traction engine, farm tractor, self-propelled implement of husbandry or road-building machine.
8. **"Municipal Parking Lot"** means accommodation provided by the City for the parking of motor vehicles off the street or highway and open for public use with or without payment as listed and shown in **Schedule "B"** hereof.
9. **"Ontario Veterans Licence Plate"** - means a licence plate issued by the Ministry of Transportation of Ontario to a vehicle owned by a Veteran, and which, at the time of parking, was driven by a Veteran or a Veteran was a passenger therein;
10. **"Occupant"**, when used in relation to real property, means,
- i. the tenant of the property or part thereof whose consent shall extend only to the control of the land of which they are a tenant and any parking spaces allotted to them under their lease or tenancy agreement.
 - ii. the spouse of a tenant.
 - iii. a person or a municipality, or a local board thereof, having an interest in the property under an easement or right-of-way granted to or expropriated by the person, municipality, or local board whose consent shall extend only to the part of the property that is subject to the easement or right-of-way.
 - iv. a person authorized in writing by an occupant as defined in sub-subclause (i), (ii), or (iii) to act on the occupant's behalf for requesting the enforcement of this By-law.

11. **"Owner"**, when used in relation to real property, means:
- i. the registered owner of the property.
 - ii. the registered owner of a condominium unit, whose consent shall extend only to the control of the owner's unit and any parking spaces allotted to the owner by the condominium corporation or reserved for the owner's exclusive use in the declaration or description of the property.
 - iii. the spouse of a person described in sub-subclause (i) or (ii).
 - iv. where the property is included in a description registered under the Condominium Act, the board of directors of the condominium corporation.
 - v. a person authorized in writing by the property owner as defined in sub-subclause (i),(ii), (iii), or (iv) to act on the owner's behalf for requesting the enforcement of this By-law.
12. **"Parking Token"** means a token approved by the Commissioner of Transportation and Public Works for use in a parking meter or in other parking control devices.
13. **"Park" or "Parking"** means the standing of a motor vehicle, whether occupied or not, except when standing temporarily for the purpose of and while actually engaged in loading or unloading merchandise or passengers.
14. **"Privately Owned Parking Lot"** means accommodation provided on private property for the parking of motor vehicles.
15. **"Parking Meter"** means:
- i. a device that can indicate thereon the length of time during which a vehicle may be parked and which shall have as parts thereof:
 - (1) a receptacle for receiving and storing coins or parking meter tokens;
 - (2) a slot or place in which such coins or tokens may be deposited;
 - (3) a timing mechanism to measure the passage of the interval of time during which the parking is permissible; and
 - (4) which displays a signal when said interval of time shall have elapsed; or,
 - ii. a device which will produce a receipt indicating the length/amount of parking time purchased and which produces a receipt indicating the amount of parking time purchased.
16. **"Parking Meter Zone"** means the Municipal Parking Lots or parts of Municipal Parking Lots designated from time to time constituting a Parking meter zone, as shown on **Schedule "B"** hereto.
17. **"Parking Permit"** means a decal or specially designed card authorized from time to time by the Commissioner of Transportation and Public Works or his/her designate that allows special parking privileges and includes:

- i. **"Courtesy Permit"** which permits the parking of a motor vehicle, without payment, in any space (except a reserved and a disabled space) in any municipal parking lot from 9:00 a.m. to 6:00 p.m. on the date indicated thereon;
 - ii. **"24/7 Permit"** which permits the parking of a motor vehicle, without payment, in any space (except a reserved space or a disabled space) in the municipal parking lot indicated on the permit twenty-four (24) hours per day during the year indicated thereon;
 - iii. **"Day Time Permit"** which permits the parking of a motor vehicle, without payment, in any reserved or other space (except disabled) in the municipal parking lot indicated thereon from 9:00 a.m. to 6:00 p.m. of each day;
 - iv. **"Car Pool Permit"** which permits the parking of a motor vehicle in any parking space designated as "Pool Permit" in the municipal parking lot indicated thereon.
18. **"Parking Space"** means a portion of the surface of a municipal parking lot or privately owned parking lot showing by pavement markings a space for the parking of a motor vehicle.
19. **"Reserved Parking Space"** means a parking space located:
- i. in a municipal parking lot as shown on **Schedule "B"** hereto; or
 - ii. in a privately owned parking lot; and
 - iii. which is identified by authorized signs indicating such space to be for the exclusive use of vehicles displaying a Parking Permit authorized by such signs.

PART II – REGULATIONS

Property other than Municipal Parking Lots

1. Application

The provisions of this Part shall apply to:

- a. property owned or occupied privately; and
- b. to property owned or occupied by the City or any local Board thereof;

but shall not apply to municipal parking lots owned, leased or operated by the City.

2. No Parking

No person shall park a motor vehicle on private property without the consent of the owner or occupant of the property nor on property owned or occupied by the City or any local Board thereof without the consent of the City or local Board, as the case may be.

3. Written Complaint

The driver or owner of a motor vehicle parked on private property is not liable to a penalty or to have the motor vehicle removed from such property or impounded except upon the written complaint of the owner or occupant of the property given to a police officer, police cadet or municipal law enforcement officer appointed for the carrying out of the provisions of this By-law.

4. **Signs**

Where an owner or occupant of property has posted signs referring to this By-law and stating conditions on which a motor vehicle may be parked on the property or prohibiting the parking of a motor vehicle on the property, a motor vehicle parked on the property contrary to such conditions or prohibition shall be deemed to have been parked without consent.

PART III – REGULATIONS

Municipal Parking Lots

1. **Application to Municipal Parking Lots**

a. The provisions of this part shall apply to City owned, leased or operated municipal parking lots, more particularly described in **Schedule "B"** attached hereto.

b. The provisions of this part do not apply to:

- i. an emergency vehicle as defined within the *Highway Traffic Act*, R.S.O. 1990, c. H. 8, as amended;
- ii. a vehicle owned by the City of by the Regional Municipality of Waterloo while actively engaged in performing municipal duties; or
- iii. vehicle owned by a public utility (including hydro, gas, water, telephone and cable) while actively engaged in performing utility services.

c. **Un-expired Time**

Any person may use the un-expired time remaining in a parking meter from its previous use.

d. **Signs**

The Commissioner of Transportation and Public Works or his/her designate is hereby authorized to place, erect, display and maintain such signs as are required to give effect to the provisions of this By-law.

e. **Substitute Coins**

No person shall deposit or cause to be deposited in any parking meter any slug, device or other substitute for a coin of the Dominion of Canada or the United States of America other than the approved City parking tokens.

2. **Parking Offences**

a. **Exceed Time Period**

Between the hours of 9:00 a.m. and 6:00 p.m. from Monday to Saturday inclusive, no person, including persons with Disabled Parking Permits, shall park in any parking space in any Municipal Parking Lot for a continuous period in excess of the maximum time shown in **Schedule "C"** unless the parking space is designated by an authorized sign that is on display as allowing longer parking for Parking Permits.

b. Payment

Save and except for persons displaying an Ontario Veterans Licence Plate, between the hours of 9:00 a.m. and 6:00 p.m., from Monday to Saturday inclusive, no person shall park a motor vehicle at a parking meter zone in any municipal parking lot unless the fee set out in **Schedule "C"** to this By-law has been deposited in the parking meter for the parking space and, where appropriate, the receipt indicating the length/amount of parking time purchased has been clearly displayed in the motor vehicle.

c. Exceed Paid Time

No person shall park a motor vehicle at a parking meter zone for a longer period than the period for which payment has been made in the parking meter.

d. Parking Permit

No person shall park a motor vehicle in any parking space that is indicated, by an authorized sign that is on display, as "Permit Parking" unless the vehicle is displaying a valid Parking Permit for that parking space.

e. Fees for Parking Permits

The fee for Parking Permits for each parking lot is as set out in **Schedule "C"** to this By-law.

f. Overnight Parking

Unless a proper Parking Permit is on display, no person shall park a motor vehicle in any Municipal Parking Lot at any time between the hours of 2:30 a.m. to 6:00 a.m. from December 1st to March 31st inclusive in each year.

g. Market Square

Notwithstanding the preceding provision, no person shall park a motor vehicle from 2:30 a.m. to 6:00 a.m. at any time during the year in the Market Square Lot.

h. Aisles

No person shall park a motor vehicle on any roadway or aisle in any Municipal Parking Lot.

i. Access Roadway

No person shall Park a motor vehicle along an access roadway to a Municipal Parking Lot.

j. In Parking Space

No person shall park a motor vehicle in a Municipal Parking Lot except in a parking space designated by markers or painted lines and as nearly in the centre of the parking space as possible.

k. **No Commercial Activity**

No person shall use any portion of any Municipal Parking Lot for the purpose of buying or selling merchandise or services or repairing of vehicles unless authorized in writing by the Commissioner of Transportation and Public Works or his/her designate.

l. **Distribute Literature or Handbills**

No person shall distribute literature or deposit handbills on or into any motor vehicle in any Municipal Parking Lot unless authorized in writing by the Commissioner of Transportation and Public Works or his/her designate.

m. **Obstruction**

No person shall park a motor vehicle in such a position as to prevent the convenient removal of any other motor vehicle previously parked or stopped.

n. **Size and Weight**

Unless authorized in writing by the Commissioner of Transportation and Public Works or his/her designate, no person shall park a motor vehicle in a Municipal Parking Lot which vehicle has:

- i. an overall length of more than 6 meters; or
- ii. an overall width of more than 2.5 meters; or
- iii. an overall weight greater than 1600 kilograms.

For the purposes of this By-law, the length and width of a motor vehicle shall include the length and width of any load carried by such motor vehicle.

o. **Temporary Stopping**

No person shall park or stop a motor vehicle in a Municipal Parking Lot area designated by an authorized sign that is on display as a "No Parking" or "Loading" zone except that a driver of a motor vehicle may temporarily stop in these zones for the purpose of, and while actually engaged in loading or unloading goods or passengers, provided that such stopping does not interfere with any other motor vehicle waiting to enter or about to enter these zones.

p. **Expired Parking Permits**

The displaying of illegible, expired, cancelled or altered Parking Permits for the purpose of a valid Parking Permit is prohibited.

q. **Lost Parking Permit**

The displaying of a Parking Permit which has been lost by its lawful owner or stolen from its lawful owner, for the purpose of a valid Parking Permit by a person knowing such permit has been lost by its lawful owner or stolen from its lawful owner is prohibited.

3. **Moving Offences**

a. **Direction**

A person shall drive in a Municipal Parking Lot only in the direction indicated by signs or pavement markings and shall drive only on the roadways.

b. **Speed**

No person shall drive on any roadway in a Municipal Parking Lot at a speed greater than 15 kilometers per hour.

c. **Entrances and Exits**

No person shall drive into or leave a Municipal Parking Lot at other than the designated entrances and exits.

d. **Endanger**

No person shall use any portion of a Municipal Parking Lot in a manner so as to endanger the person or property of another.

PART IV – ENFORCEMENT AND PENALTY

1. **Offences**

a. Any person who contravenes any provision of Part II of this By-law is guilty of an offence and, upon conviction, is liable to a fine as provided for in the *Provincial Offences Act*, R.S.O. 1990, c. P. 33, as amended;

b. The set fine for each offence under Part II herein is set out in **Schedule “D”** of this By-law;

c. Any person who contravenes any provision of Part III of this by-law is guilty of an offence and, upon conviction, is liable to a fine as provided for in the *Provincial Offences Act*, R.S.O., 1990, c. P. 33, as amended.

d. The set fine for each offence under Part III herein is set out in **Schedule “E”** of this By-law;

e. If the set fine is not paid within the time period required, the procedures of the Provincial Offences Act, R.S.O., 1990, c. P. 33, as amended, shall apply.

f. All provisions of this By-law may be enforced by Enforcing Officials provided that moving offences may only be enforced by a police officer.

g. Notwithstanding the preceding provision, Enforcing Officials whose names appear in **Schedule “A”** hereto may enforce the provisions of this By-law only on a property the municipal address of which is listed beside their name in said **Schedule “A”**.

2. Removal of Vehicle

A Police Officer of the Regional Municipality of Waterloo Police Service upon discovery of any motor vehicle parked in contravention of the provisions of this By-law, may cause it to be moved or taken to and placed or stored in a suitable place and all costs and charges for removing, care and storage thereof, if any, are a lien upon the motor vehicle, which may be enforced in the manner provided by the *Repair and Storage Liens Act*, R.S.O., 1990, Chapter R. 25.

3. Owner and Driver

The driver of a motor vehicle, not being the owner, is liable for any penalty provided in this By-law and the owner of the motor vehicle is also liable to such penalty unless at the time the offence was committed the motor vehicle was in the possession of a person other than the owner without the consent of the owner.

PART V - GENERAL

1. Sever

Should any part, section or provision of this By-law be declared by a Court of competent jurisdiction to be invalid, the same shall not effect the validity of the By-law as a whole or in part thereof, other than the part which was declared to be invalid.

2. Citation

This By-law may be referred to as the Private and Municipal Property Parking By-law.

3. Effective Date

This By-law shall come into force and take effect on January 1, 2007.

READ A FIRST, SECOND, AND THIRD TIME,
ENACTED AND PASSED THE 18TH DAY OF SEPTEMBER, 2006.

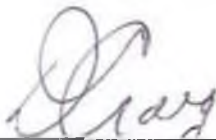

MAYOR



DEPUTY CITY CLERK

**SCHEDULE 'A' TO BY-LAW NO.62
OF
THE CORPORATION OF THE CITY OF CAMBRIDGE**

Municipal Address and Area of Jurisdiction	Name	By-law No.
A		
4 Albert Street	Fred Danchuk	208-01
B		
821 & 823 Barbara Court	Lucia Mignella	242-00
129-157 Bechtel Street	Ahmadullah Amiri	276-05
175 Beverly Street	Bill Bender	
175 Beverly Street	James Bennett	
175 Beverly Street	Trefor Cocks	
175 Beverly Street	Robert Hamilton	
245 Bishop Street	Brenda Anderson	194-98
245 Bishop Street	Derek Harris	
245 Bishop Street	John Fraser	194-98
245 Bishop Street	Norma Thiessen	
245 Bishop Street	Tracy Weir	194-98
1305 Bishop Street	Tom Smith	
1730 Bishop Street	Pam Mather	90-00
C		
944 Caledonian View	Pam Mather	90-00
175 Cedar Street	Ahmadullah Amiri	276-05
190 Cedar Street	Angelo Paivo	264-00
190 Cedar Street	Lidia Paivo	
190 Cedar Street	Kimberly Sousa	
135 Chalmers Street S	Cheryl DesLauriers	131-99
135 Chalmers Street S	J. Edward DesLauriers	131-99
135 Chalmers Street S	Edmund Pereira	
125 Champlain Boulevard	Ahmadullah Amiri	276-05
380 Champlain Boulevard	Pam Mather	90-00
700 Champlain Boulevard	Sandra Custodio	73-04
700 Champlain Boulevard	Shelia Mojica	176-04
700 Champlain Boulevard	Sandra Custodio	
272 Clyde Road	Eduarda Silva	
143 Concession Road	Ahmadullah Amiri	276-05
10 Cooper Street	Reid Little	95-98
10 Cooper Street & 40-42 Tannery Street	Melanie DeHaan	
10 Cooper Street & 40-42 Tannery Street	William DeHaan	
10 Cooper Street & 40-42 Tannery Street	Darlene Lockston	
10 Cooper Street & 40-42 Tannery Street	Ronald Powell	
581 Coronation Boulevard	Murray Lusk	8-98
581 Coronation Boulevard	Mary McAulay	8-98
581 Coronation Boulevard	John McGrath	40-06
581 Coronation Boulevard	George McLeod	8-98
581 Coronation Boulevard	Art White	
614 Coronation Boulevard	Marg Dykeman	
614 Coronation Boulevard	Joanne Hamilton-Smith	
614 Coronation Boulevard	Robert Hanna	
650 Coronation Boulevard	Joanne Hamilton-Smith	
650 Coronation Boulevard	Robert Hanna	

**SCHEDULE 'A' TO BY-LAW NO.62
OF
THE CORPORATION OF THE CITY OF CAMBRIDGE**

Municipal Address and Area of Jurisdiction	Name	By-law No.
695 Coronation Boulevard	Louise Lawrie	85-05
697 Coronation Boulevard	Mitzi Bryant	260-04
700 Coronation Boulevard (CMH)	Ryan Burroughs	54-03
700 Coronation Boulevard (CMH)	Ryan A. Comfort	245-05
700 Coronation Boulevard (CMH)	Randell N. Cramp	245-05
700 Coronation Boulevard (CMH)	Alexander Frenzel	54-03
700 Coronation Boulevard (CMH)	Tammy Lynn Leirsch	123-03
700 Coronation Boulevard (CMH)	Trevor Russell	194-03
700 Coronation Boulevard (CMH)	Troy G. Vollet	245-05
700 Coronation Boulevard (CMH)	Josh Tischart	261-04
725 Coronation Boulevard	Susan Hall	
725 Coronation Boulevard	Robert Stephens	
725 Coronation Boulevard	Marg Wagner	28-99
D		
40 Dickson Street (Market Building)	Doug McDowell	66-02
56 Dickson Street	Donna Jewell	
455 Dundas Street	Joseph Fittante	
E		
650 Eagle Street N	Hilda Smellie	
2445 Eagle Street	Patti Winer	
487 Elgin Street N	Ahmadullah Amiri	77-06
487 Elgin Street N	Susan Clements	52-04
825 Elgin Street N	Tom Forestell	
825 Elgin Street N	Donna McKay	
825 Elgin Street N	Nick Roehrig	
825 Elgin Street N	Rosemary Wehrle	
930 Elgin Street N	Wendell Arsenault	
930 Elgin Street N	John Kain	218-04
930 Elgin Street N	John Mascoll	
930 Elgin Street N	Sherry McKinlay	
930 Elgin Street N	Michelle Spinks	
930 Elgin Street N	Alexander Tipple	218-04
F		
101 Franklin Blvd.	Anne McLoughlin	183-04
101 Franklin Blvd	Chris Szeles	230-05
800 Franklin Boulevard	Andrew Moffat	
G		
86-96 Gail Street	Ahmadullah Amiri	276-05
415-435 Garden Street	Richard Chamberlin	
415-435 Garden Street	Rose Marie Chamberlin	
65 Glamis Road	Chris Flis	27-99
65 Glamis Road	Denis McQuoid	47-98
66 Glamis Road	Ahmadullah Amiri	77-06
66 Glamis Road	Susan Clements	52-04
210 Glamis Road	Ahmadullah Amiri	276-05
210 Glamis Road	Doug Streit	
215 Glamis Road	Lisa Cummings	224-98
215 Glamis Road	Lynn Nyers	

**SCHEDULE 'A' TO BY-LAW NO.62
OF
THE CORPORATION OF THE CITY OF CAMBRIDGE**

Municipal Address and Area of Jurisdiction	Name	By-law No.
64 Grand Avenue S	Leslie Biggs	199-01
H		
1242 Hamilton Street	Ken Huber	
1242 Hamilton Street	Liz Huber	
25 Harris Street	Diane DeCoene	
190 Hespeler Road	Ahmadullah Amiri	276-05
190 Hespeler Road	Gabriel Shields	
190 Hespeler Road	Doug Streit	
190 Hespeler Road	Bill Thompson	
204-A Hespeler Road	Esther Lunn	
204-B Hespeler Road	Esther Lunn	
355 Hespeler Road (Cambridge Centre)	Allan Dilly	
355 Hespeler Road (Cambridge Centre)	Ryan Coon	127-03
355 Hespeler Road (Cambridge Centre)	Jean Currie	
355 Hespeler Road (Cambridge Centre)	Allan Dilly	223-01
355 Hespeler Road (Cambridge Centre)	Michael Ennis	32-06
355 Hespeler Road (Cambridge Centre)	Keli Falkiner	127-03
355 Hespeler Road (Cambridge Centre)	Nick Feren	127-03
355 Hespeler Road (Cambridge Centre)	Adam Houser	32-06
355 Hespeler Road (Cambridge Centre)	Jacob Johnston	32-06
355 Hespeler Road (Cambridge Centre)	David Kitchen	127-03
355 Hespeler Road (Cambridge Centre)	Jennifer Kotsamanes	127-03
355 Hespeler Road (Cambridge Centre)	David Lavery	127-03
355 Hespeler Road (Cambridge Centre)	Nicholaus Mooney	127-03
355 Hespeler Road (Cambridge Centre)	Frank O'Brien	
355 Hespeler Road (Cambridge Centre)	John Rothwell	
355 Hespeler Road (Cambridge Centre)	Vikinderjeet Sandhi	127-03
355 Hespeler Road (Cambridge Centre)	Kristen VanDerGeld	127-03
550 Hespeler Road	Piero Bagnara	161-00
150 Holiday Inn Drive	Jeff Pelley	88-05
200 Holiday Inn Drive	Andrew Moffat	
240 Holiday Inn Drive	Harry Degroot	
355 Holiday Inn Drive (Jacob Hespeler SS)	Ron Lesperance	64-05
375 Holiday Inn Drive	Pam Haig	242-05
375 Holiday Inn Drive	Wayne Kappler	242-04
375 Holiday Inn Drive	Pam Mather	69-02
375 Holiday Inn Drive	Wayne Kappler	98-03
Plan 521, Part Lots 19 & 20, South Side Part 2 of 58R11440, Parking lot adjacent to south side of		
I		
10 Isherwood Avenue	Pam Mather	69-02
J		
6 Jaffray Street	Murray Lusk	77-98
6 Jaffray Street	Mary McAulay	77-98
6 Jaffray Street	John McGrath	40-06
6 Jaffray Street	George McLeod	77-98
K		
237 King Street W	Ahmadullah Amiri	276-05
237 King Street W	Pam Mather	
237 King Street W	Doug Streit	
807 King Street E	David Johnson	

**SCHEDULE 'A' TO BY-LAW NO.62
OF
THE CORPORATION OF THE CITY OF CAMBRIDGE**

Municipal Address and Area of Jurisdiction	Name	By-law No.
1195 King Street W	Tony Prior	
1195 King Street E	Tony Prior	
1195 King Street E	Daniel B. Tran	214-00
1195 King Street E	Linda Prior	70-05
1195 King Street W	Don Wickie	180-00
L		
581-595 Lang's Drive	Ahmadullah Amiri	276-05
340, 350, 355 & 360 Linden Drive	Connie Bickford	180-00
340, 350, 355 & 360 Linden Drive	Lisa Mimba	
340, 350, 355 & 360 Linden Drive	Natalie Olive	67-05
340, 350, 355 & 360 Linden Drive	Tony Prior	180-00
340, 350, 355 & 360 Linden Drive	Cathy Shafe	109-98
340, 350, 355 & 360 Linden Drive	Daniel B. Tran	214-00
M		
55 Magor Drive	Ahmadullah Amiri	276-05
150 Main Street	Krista Bowmaster	89-06
150 Main Street	Mathew Landowski	89-06
150 Main Street	Peter Mercado	89-06
150 Main Street	Jason Montgomery	176-03
150 Main Street	Lukasz Ozga	89-06
150 Main Street	Kenneth Purvis	89-06
150 Main Street	John Ursu	89-06
151 Main Street	Frank Beke	
152 Main Street	Frank Beke	
550 & 562 Margaret Street	Dale Shingler	
550 & 562 Margaret Street	Richard Shingler	
140 McGovern Dr. Pam Mather		69-02
55 McKay Street (Glenview Park SS)	Bruce Deacon	
55 McKay Street (Glenview Park SS)	Larry Hamilton	
55 McKay Street (Glenview Park SS)	Brian Heggie	
55 McKay Street (Glenview Park SS)	Penny Young	170-01
10 Mill Creek Road	Mark Sealey	116-06
95 Morning Calm Drive	Frank Fera	
95 Morning Calm Drive	Aires Couto	
70 Mulberry Drive	Ahmadullah Amiri	276-05
185 Myers Road (Monsignor Doyle)	Bonnie Purdy	182-02
185 Myers Road (Monsignor Doyle)	Ena Kearney	182-02
185 Myers Road (Monsignor Doyle)	Wendy Price	54-00
185 Myers Road (Monsignor Doyle)	Frank Johnson	54-00
185 Myers Road (Monsignor Doyle)	Michael Schmidt	
185 Myers Road (Monsignor Doyle)	Bernie Farwell	
325 Myers Road	Wally Thompson	
N		
O		
P		
785,789,793,797 Patterson Place	Neil Eaket	260-99
633 Parkview Crescent	Blair Cochrane	224-98
633 Parkview Crescent	Darlene Maude	
633 Parkview Crescent	Marlene Pratt	224-98

**SCHEDULE 'A' TO BY-LAW NO.62
OF
THE CORPORATION OF THE CITY OF CAMBRIDGE**

Municipal Address and Area of Jurisdiction	Name	By-law No.
26 Poplar Drive	Ahmadullah Amiri	276-05
Q		
182 Queen Street	Derich Butler	
182 Queen Street	Robert Hamilton	
182 Queen Street	Robert Hunter	
1009 Queenston Road	Doug Streit	57-00
1031 Queenston Road	Al Wilson	
1031 Queenston Road	Neil Koebel	
1510 Queenston Road	Barbara Wanzo	
1510 Queenston Road	William Wanzo	
1580 Queenston Road	William Barlow	
R		
99-141 Rouse Avenue	Ahmadullah Amiri	276-05
S		
50 Saginaw Parkway	Greg Bester	174-01
50 Saginaw Parkway	Donna McKay	210-00
50 Saginaw Parkway	Jamie McKinnon	210-00
50 Saginaw Parkway	Paul Tratnyek	210-00
199 Saginaw Parkway	Ahmadullah Amiri	276-05
199 Saginaw Parkway	Pam Mather	90-00
199 Saginaw Parkway	Doug Streit	211-00
335 Saginaw Parkway	Christine Mortaley	56-00
125 Sekura Crescent	Deanne Major	
133 Sekura Crescent	Ron Bauwmeester	
133 Sekura Crescent	Chris Glover	
133 Sekura Crescent	Frank Fera	
133 Sekura Crescent	Tom Shell	
30 Southwood Drive	David Spence	243-00
30 Southwood Drive	Brad Sims	243-00
241 Southwood Drive	Ahmadullah Amiri	276-05
263 St. Andrews Street	John Beer	
263 St. Andrews Street	Dieter Lesseman	
T		
U		
V		
W		
36 Water Street S (The Ventin Group)	Roberto Martinez	137-04
200 Water Street N (GCI)	Cathy Campbell	
200 Water Street N (GCI)	Nelson Cuthbert	
200 Water Street N (GCI)	Brian Heggie	
200 Water Street N (GCI)	Elaine Hughes	161-00
200 Water Street N (GCI)	Diane Mooney	161-00
200 Water Street N (GCI)	Janet Robson	161-00
735 Walter Street	Armenio Cortesao Serrador	172-98
791 Walter Street	Neil Eaket	260-99

SCHEDULE 'A' TO BY-LAW NO.62
OF
THE CORPORATION OF THE CITY OF CAMBRIDGE

Municipal Address and Area of Jurisdiction	Name	By-law No.
---	------	------------

21 Wellington Street	Andrew Slawek	41-98
112 Westminster Drive S	Stephen Halicki	17-03
527 William Street	Peter Bouktsis	

X
Y
Z

SCHEDULE 'B' TO BY-LAW NO.62
OF
THE CORPORATION OF THE CITY OF CAMBRIDGE

**Municipal Address and
Area of Jurisdiction**

A

Adam Street Lot
Ainslie Street Lot
Argyle Street Lot

B

Barradell's Loft
Beverly Street Lot

C

Cambridge Place
Civic Square Lot

D

Dickson Street Lot
Dover Street Lot
Duke Street Lot

E

F

Fire Hall Lot (Hespeler)
Fire Hall Lot (Preston)

G

Galt Tile Lot
Grand Avenue Lot

H

I

J

K

King Street Lot

L

Library & Gallery Lot

M

Main Street Lot
Market Square Lot
Mill Street Lot

N

O

P

Park Hill Road Lot
Preston Heights Lot #1
Preston Heights Lot #2
Preston Heights Lot #3
Preston Heights Lot #4
Preston Heights Lot #5

Q

Queenston Road Lot

**SCHEDULE 'B' TO BY-LAW NO.62
OF
THE CORPORATION OF THE CITY OF CAMBRIDGE**

**Municipal Address and
Area of Jurisdiction**

R

S

St. James Church Lot

T

Thorne Street Lot

U

V

W

Water Street Lot #1

Water Street Lot #2

Westminster Drive Lot

X

Y

Z

ATTACHED TO AND FORMING PART OF BY-LAW 186-06

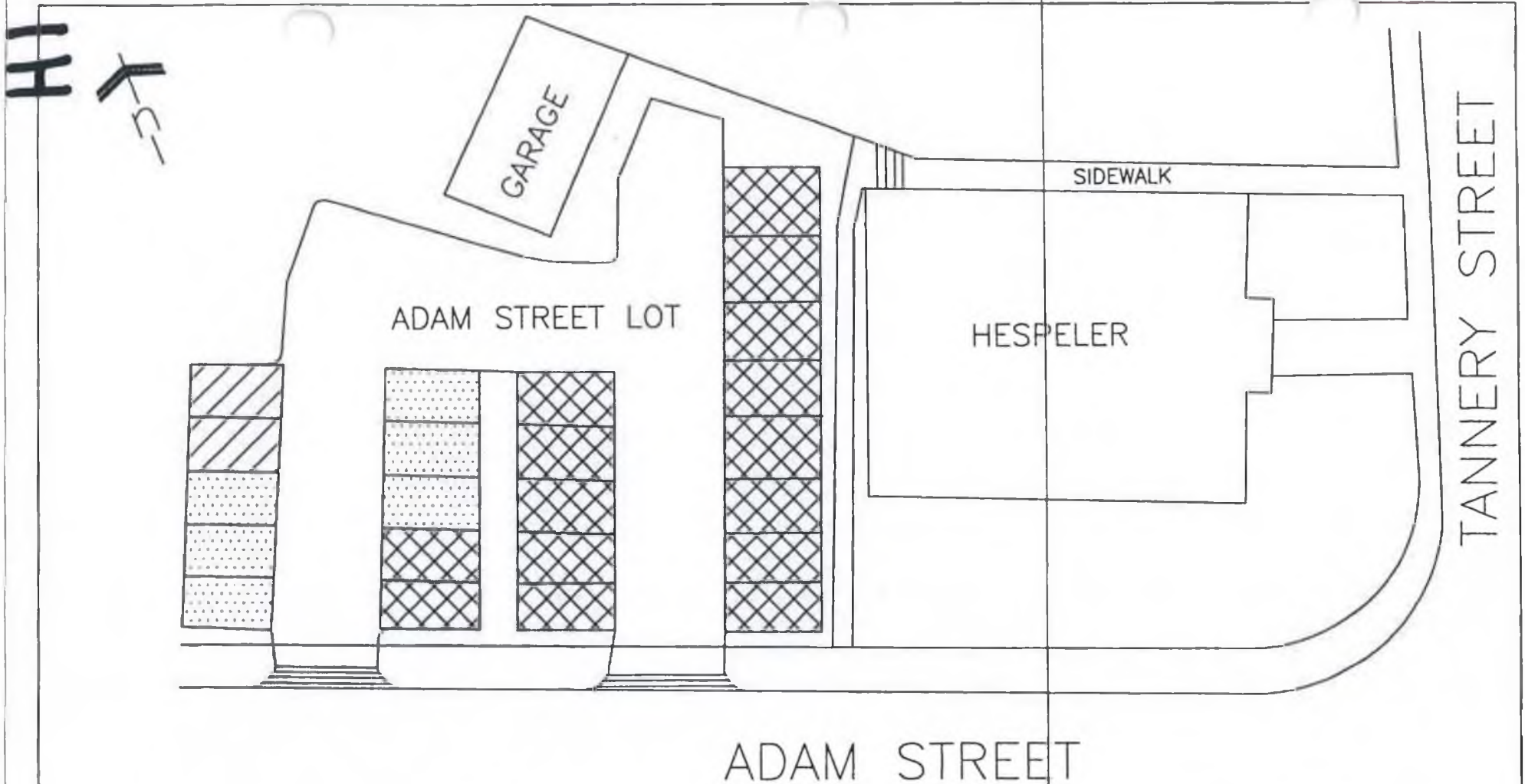

2 hour parking
Mon.-Sat. 9:00a.m.-6:00p.m.

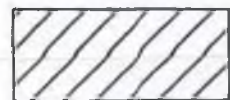

Permit Parking
24 hours a day



12 Hour Parking
Mon.-Sat. 9:00a.m.-6:00p.m.

Title		ADAM STREET PARKING LOT -24 Spaces-	
No.		By	Date
1.	Revisions to Parking	HD	June 2006
Drawn By: J. Currie		Not To Scale	
Checked By: Dave Maidment		TR-148	
Date: Aug., 1993			

ATTACHED TO AND FORMING PART OF BY-LAW 186-06

G13

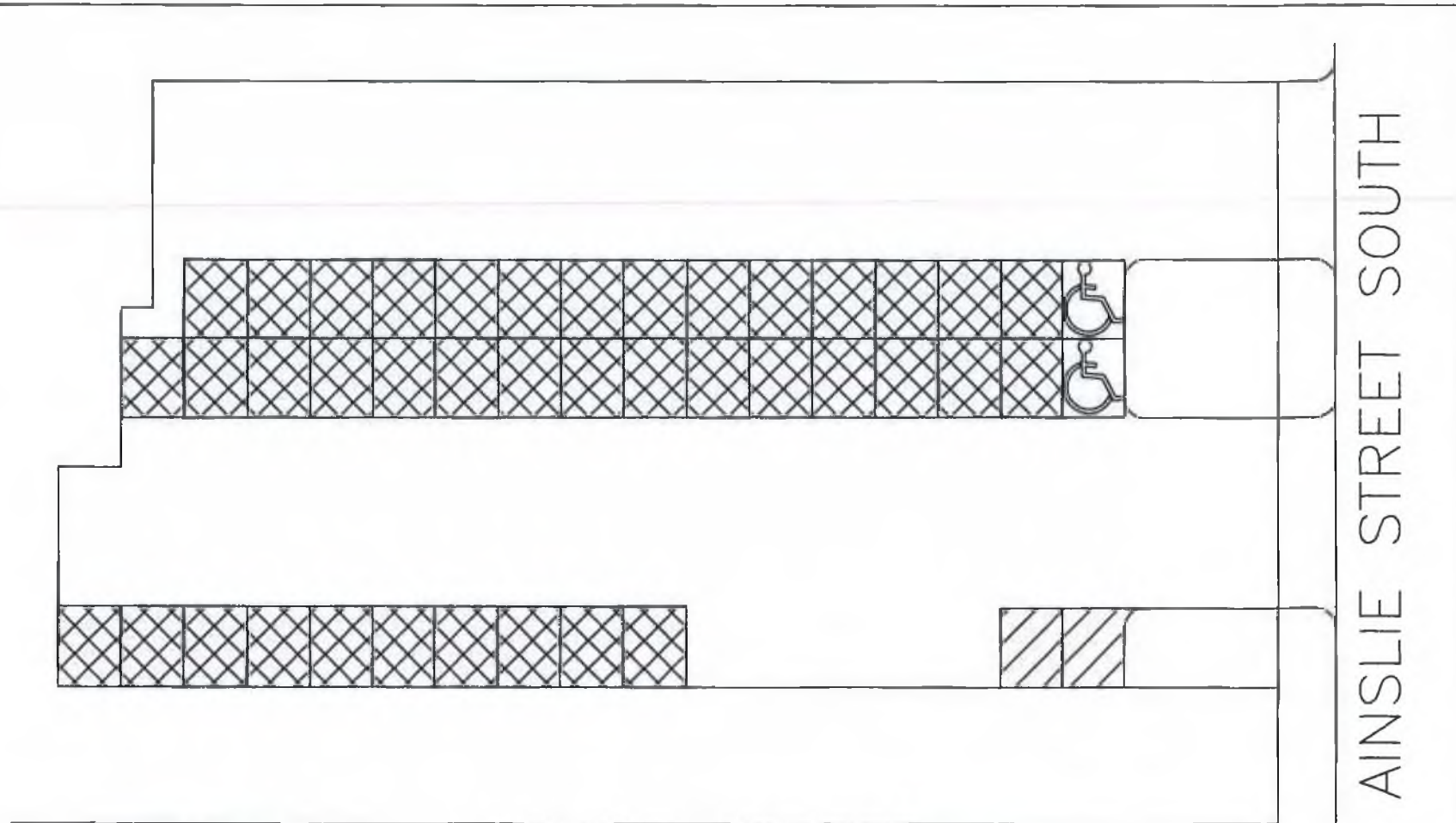

Legend: BRUCE STREET

-  DISABLED PARKING
-  12 hours free parking
Mon.-Sat, 9:00a.m.-6:00p.m.
-  Permit Parking
Mon.-Sat, 9:00a.m.-6:00p.m.

Title			
Ainslie Street South Lot -43 Spaces-			
No.	Revisions	By	Date
1.	Revisions to Permit Parking	HD	June 2006
Drawn By: Kim Thomas		Not To Scale	
Checked By: Dave Maidment		TR-102B	
Date: July, 2001			

P3

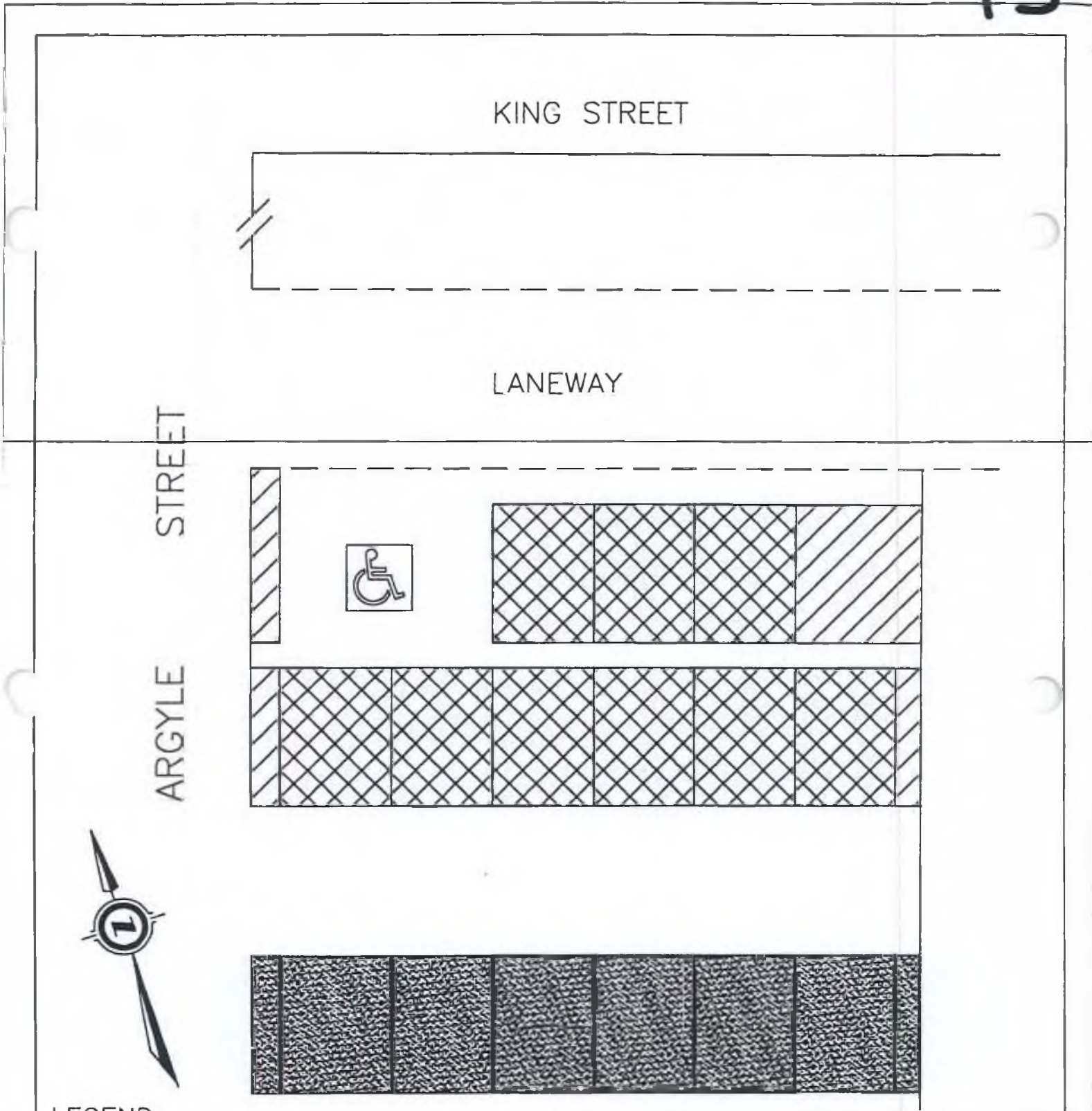

LEGEND:



DISABLED PARKING



2 HOUR FREE PARKING
MON.-SAT. 9:00a.m.-6:00p.m.



PERMIT PARKING
MON.-SAT. 9:00a.m.-6:00p.m.

Title				ARGYLE STREET LOT			
No.	Revisions		By	Date			
1.	Permit Parking		HD	Date			
Drawn By: Kim Thomas			Scale : Not to Scale				
Checked By: D.Maidment			TR-117B				
Date: Jan., 2003							

614

ATTACHED TO AND FORMING PART OF BY-LAW 186-06

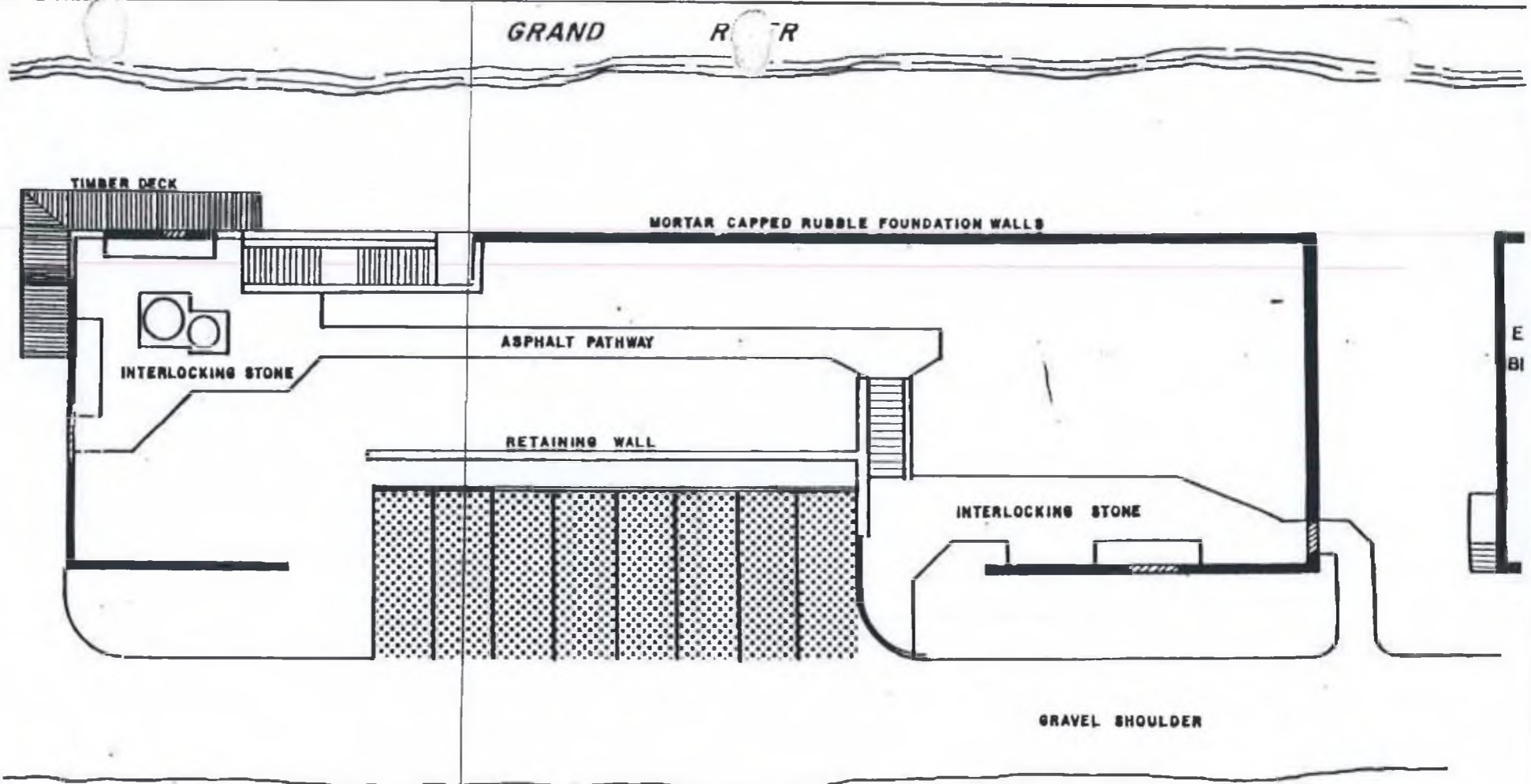

WATER STREET SOUTH



 PERMIT PARKING
 Mon. - Fri. 9:00 a.m. to 6:00 p.m.

BARRADELL'S LOFT
 8 SPACES

BARRADELL'S LOFT (SPRINCO RUIP)			
NO.	REVISIONS	BY	DATE
Drawn by: J. CURRIE		NOT TO SCALE	
Checked by: D. M.		Standard No.	
Date: AUGUST 6, 1993		TR - 200	

ATTACHED TO AND FORMING PART OF BY-LAW 186-06

68

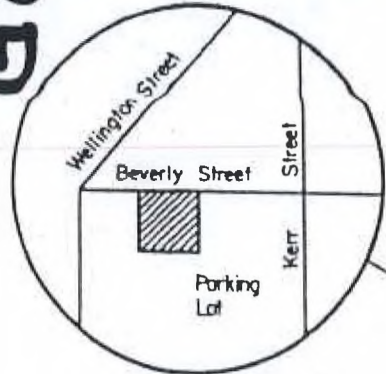

KEY MAP

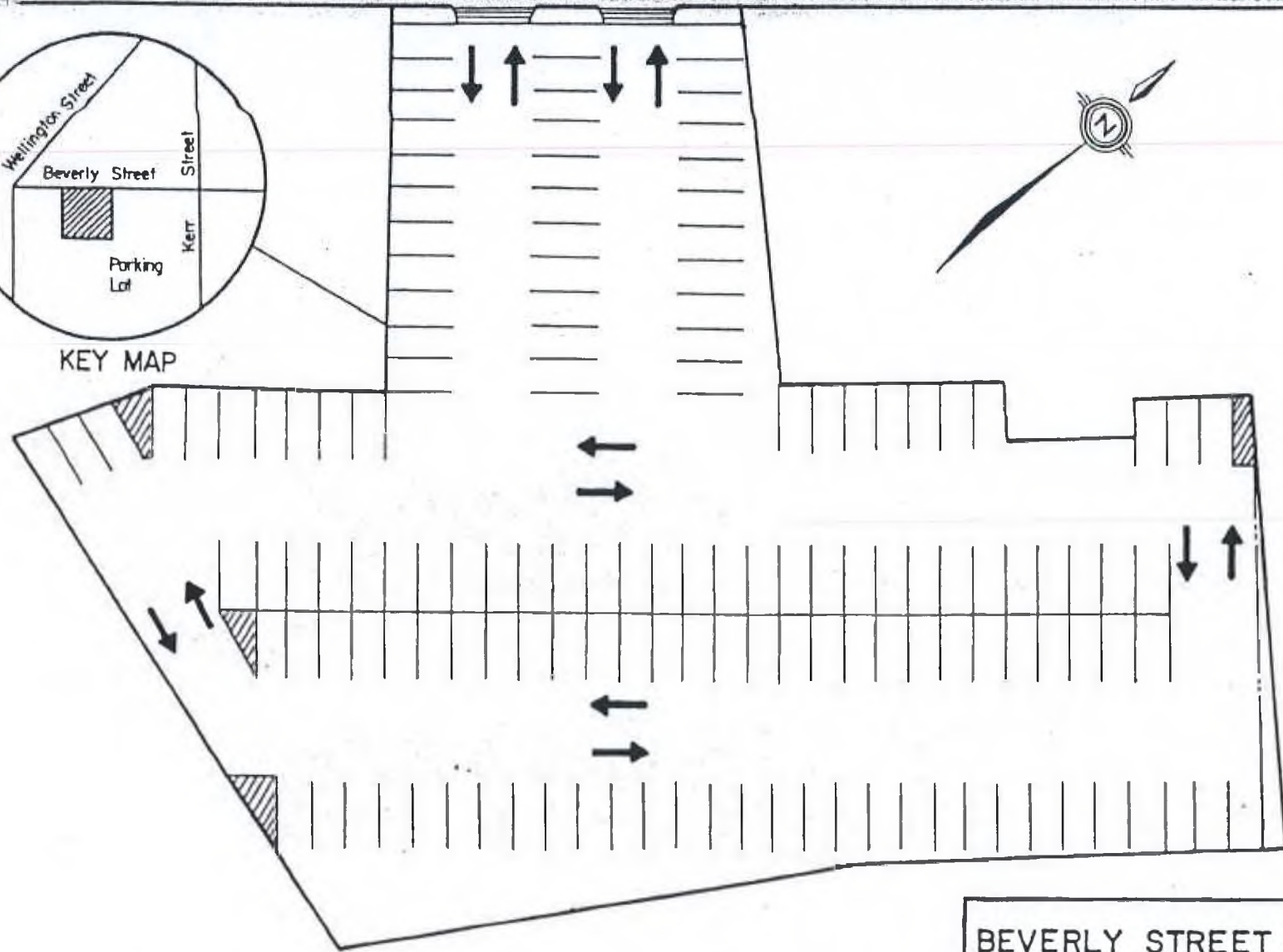

142 PARKING SPACES

12 HOURS FREE PARKING
SAT. 9:00am.-6:00p.m.

BEVERLY STREET - LOT LAYOUT

NO.	REVISIONS	BY	DATE

Drawn by: CATHIE S. NOT TO SCALE

Checked by: ANNA McK. Standard No.

Date: 15, JUNE, 1988.

R - 149

64

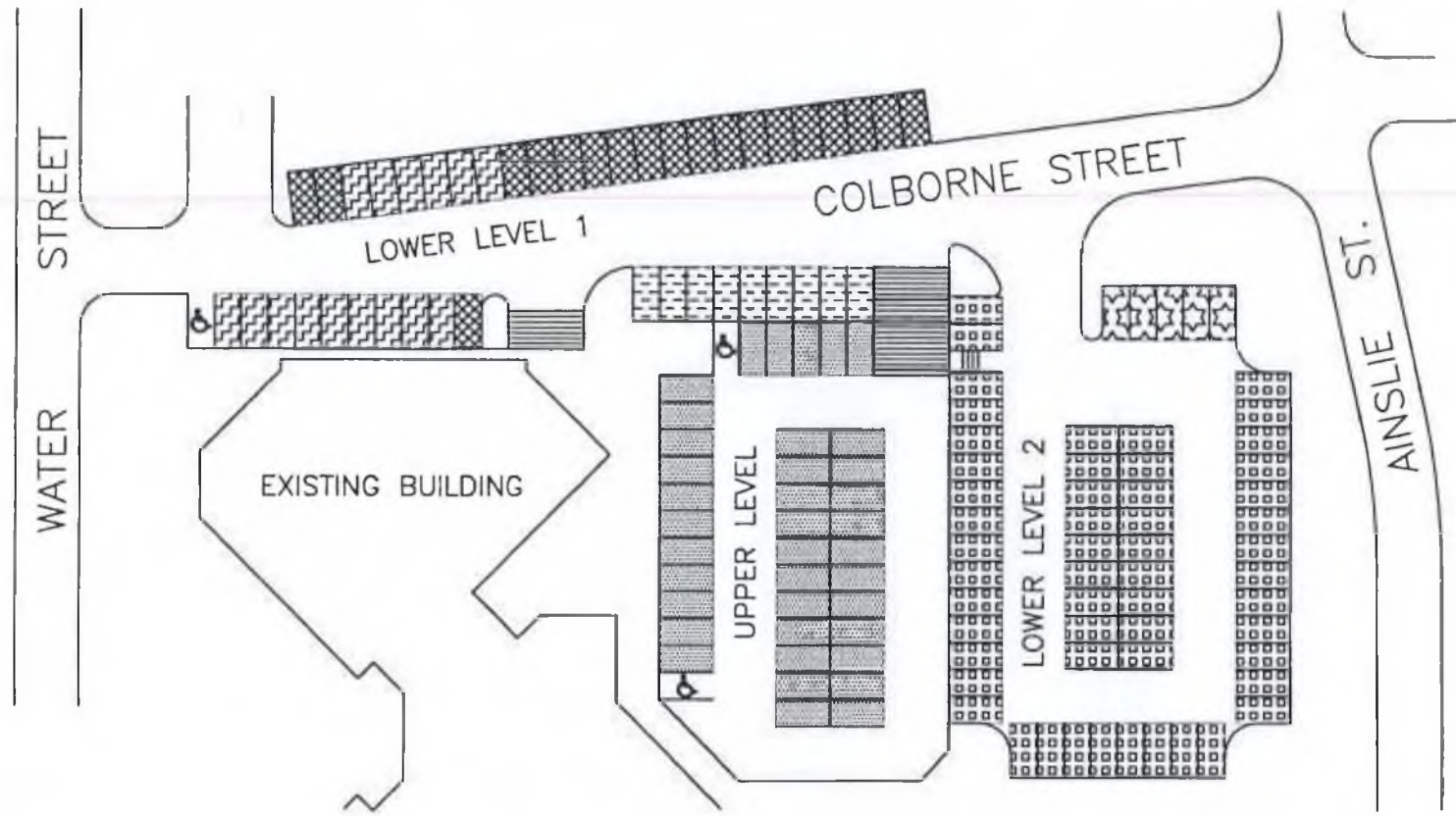

LEGEND

DISABLED PARKING ZONE

UPPER LEVEL

1 HOUR FREE PARKING AND 'CAMBRIDGE PLACE' PERMIT HOLDERS

LOWER LEVEL 1

2 HOUR FREE PARKING AND 'CAMBRIDGE PLACE' PERMIT HOLDERS

PERMIT PARKING FOR 'GRADE EXPECTATIONS' PERMIT HOLDERS

CITY EMPLOYEE PARKING ZONE

LOWER LEVEL 2

PERMIT AREA FOR CITY OF CAMBRIDGE STAFF PERMIT HOLDERS



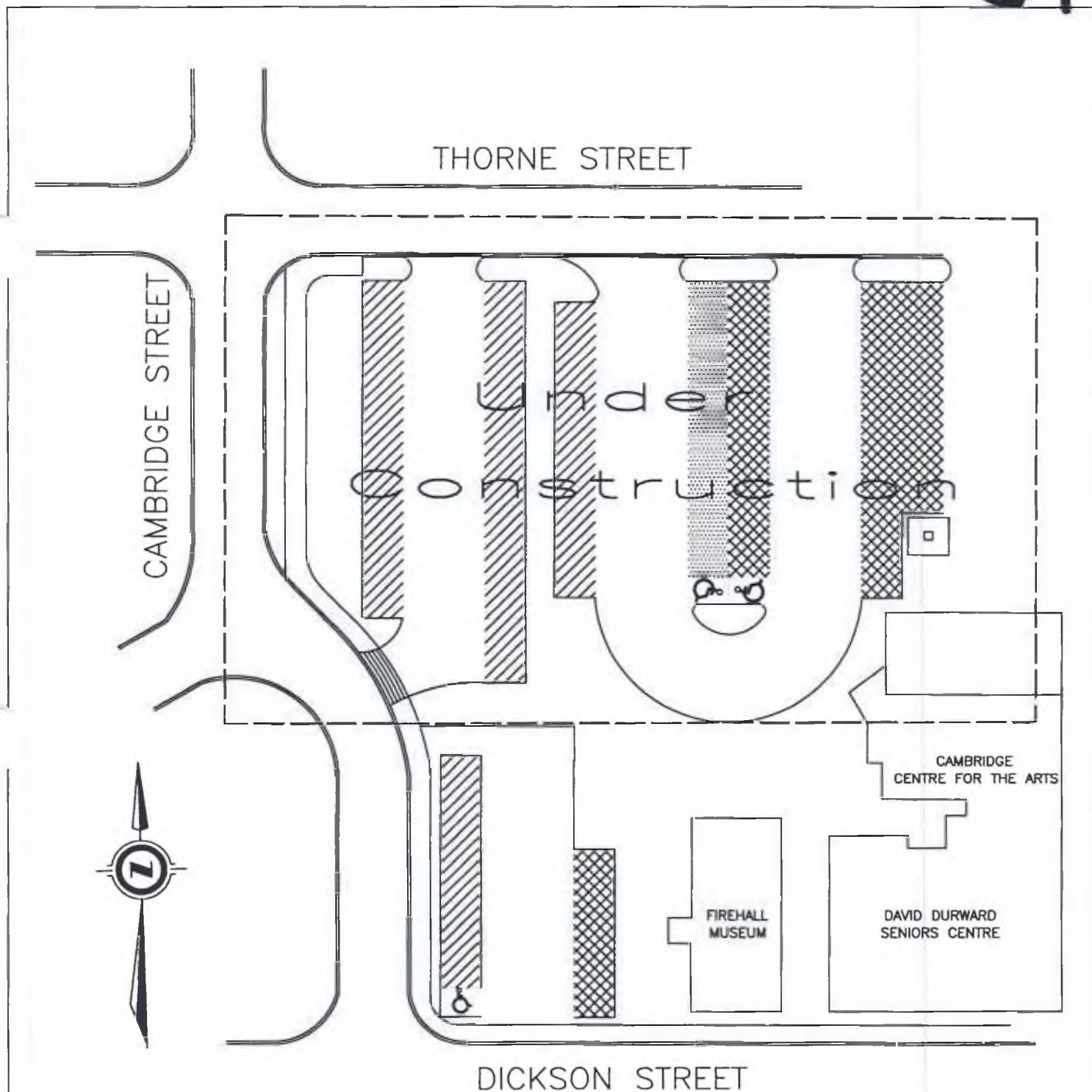

PERMIT AREA FOR PARKING BY LEASEE AND 'CAMBRIDGE PLACE' PERMIT HOLDERS

Title		CAMBRIDGE PLACE	
		73 WATER ST. NORTH	
No.	Revisions	By	Date
1.	Permit Parking	HD	June 2006
Drawn By: Kim Thomas		Not To Scale	
Checked By: M. Gilbert		TR-150	
Date: July, 2004			

G7



LEGEND:

-  PERMIT PARKING DAVID DURWARD CENTRE
-  PERMIT PARKING
-  2 HOUR PARKING
-  DISABLED PARKING

Title			
CAMBRIDGE CIVIC SQUARE			
No.	Revisions	By	Date
1.	Revision to Permit Parking	HD	June 2006
1.	Addition of Disabled Parking	HD	August 2006
Drawn By: Kim Thomas		Scale : Not to Scale	
Checked By: D.Maidment		TR-277	
Date: Jan., 2003			



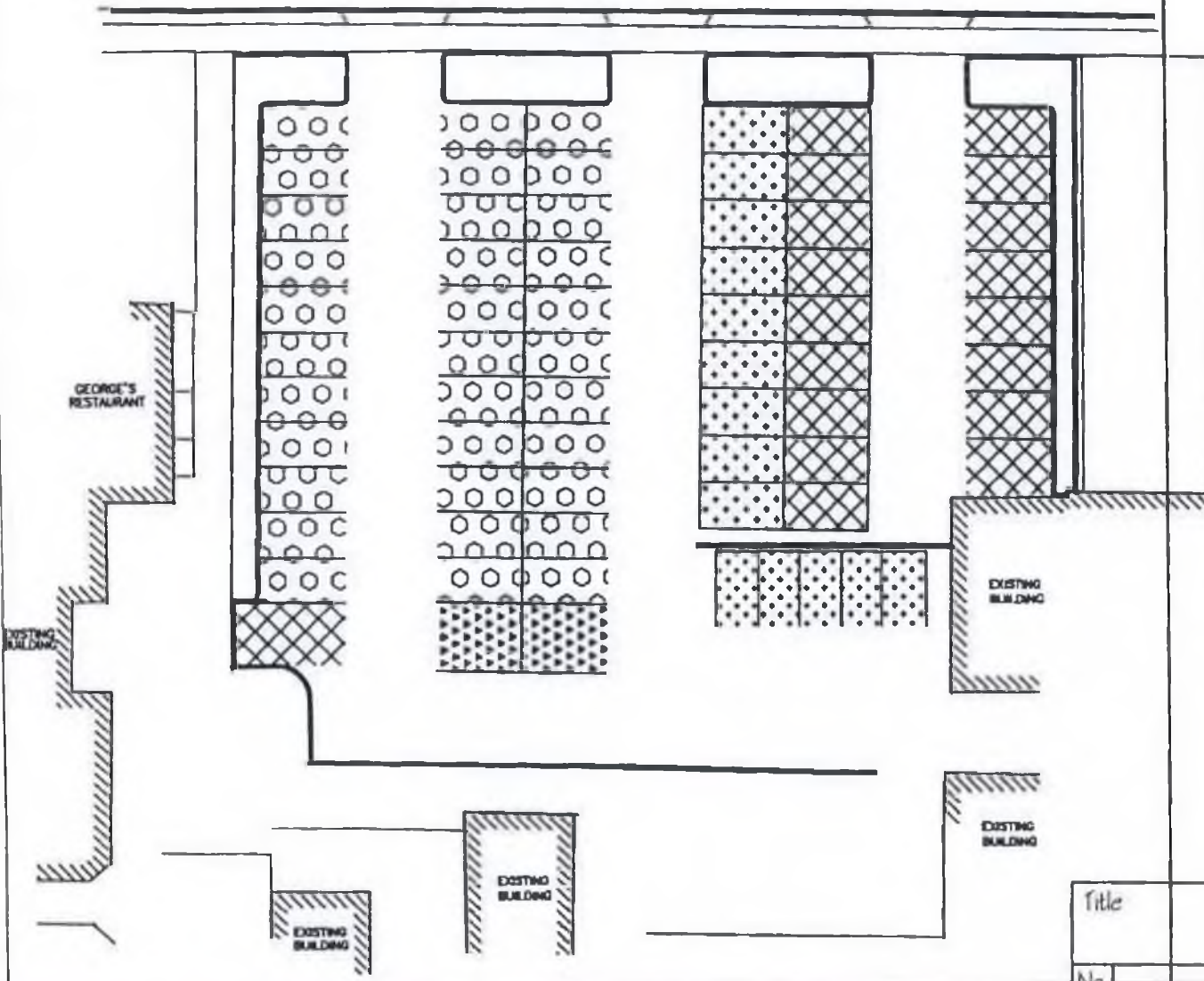

GS

DICKSON STREET



EXISTING BUILDING

LEGEND:

-  Permit Parking
Mon.-Sat., 9:00 a.m.-6:00 p.m.
-  1 hr. Free Parking
Mon.-Sat., 9:00 a.m.-6:00 p.m.
-  Disabled Parking
2 hrs. Free
Mon.-Sat., 9:00 a.m.-6:00 p.m.
-  2 hrs. Free Parking
Mon.-Sat., 9:00 a.m.-6:00 p.m.

Title				DICKSON STREET/ CANADA TRUST PARKING LOT			
No.	Revisions	By	Date				
1	Plan set update	RT	March 2008				
2	Revised	RT	Sept. 2009				
3	Permit Parking	RT	June 2010				
Drawn By: Kim Thomas		Not To Scale					
Checked By:		TR-247					
Date:							



GS

ATTACHED TO AND FORMING PART OF BY-LAW 186-06

KING STREET

DOVER STREET

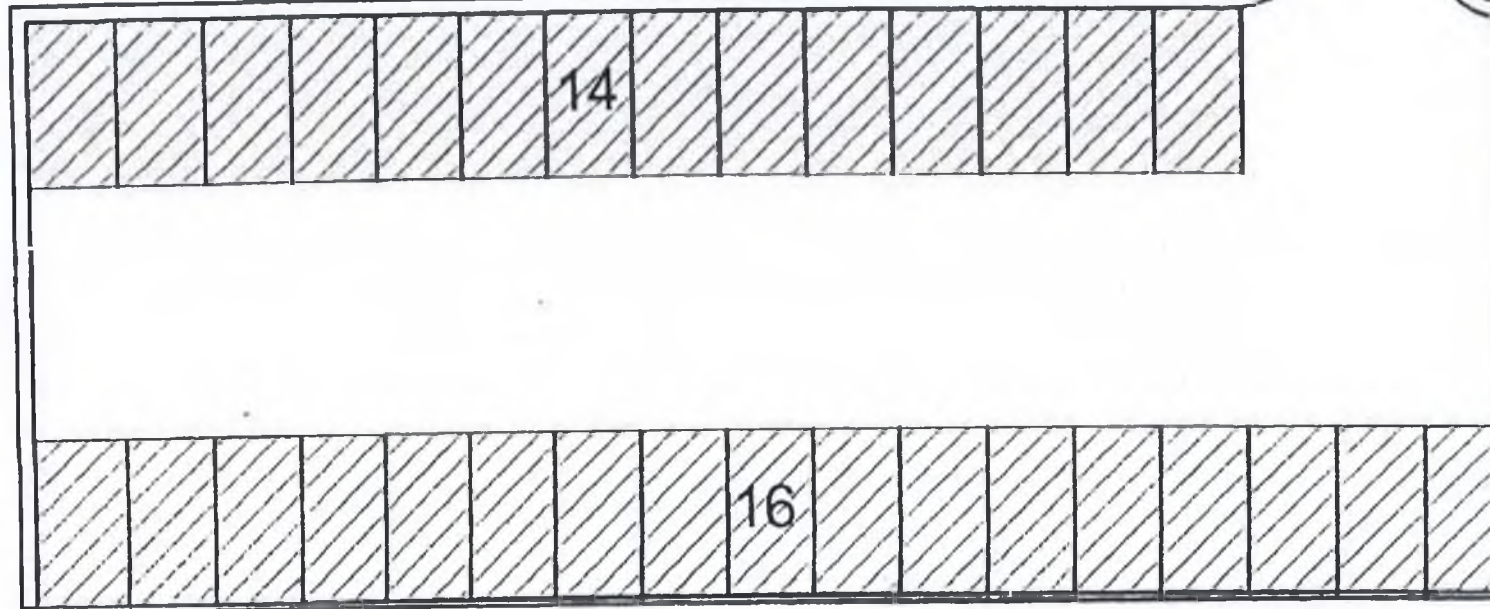

LEGEND



12 HOURS FREE PARKING
 MON. TO SAT.
 9:00a.m. TO 6:00p.m.

Title				DOVER STREET LOT			
				30 SPACES			
No.	Revisions			By	Date		
Drawn By: Kim Thomas				Scale : Not to Scale			
Checked By: D.Maidment				TR-275			
Date: Dec., 2002							

PI

ATTACHED TO AND FORMING PART OF BY-LAW 186-06

-DUKE STREET LOT-
28 SPACES

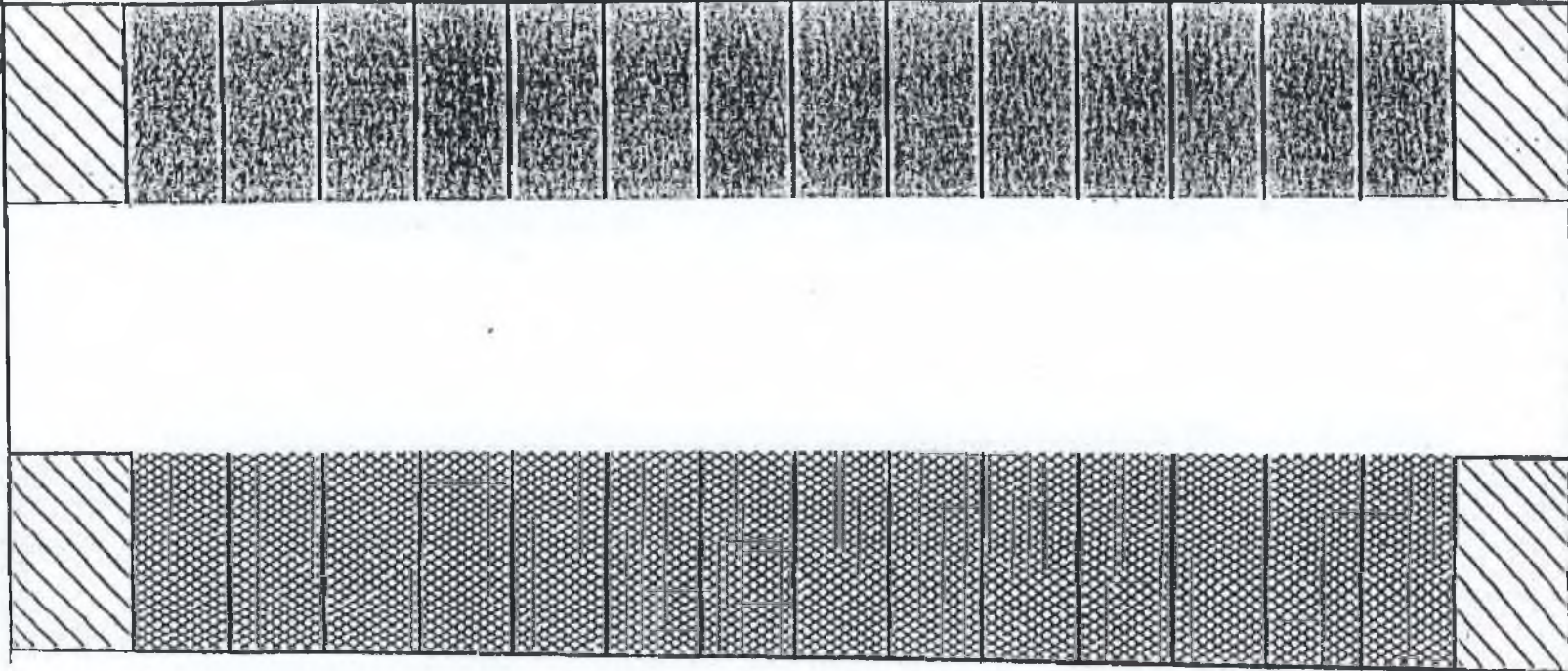

DUKE STREET

LEGEND

-  PERMIT PARKING
MON.-SAT. 9:00a.m. - 6:00p.m.
-  2 HOUR FREE PARKING
MON.-SAT. 9:00a.m. - 6:00p.m.

ATTACHED TO AND FORMING PART OF BY-LAW 186-06

24

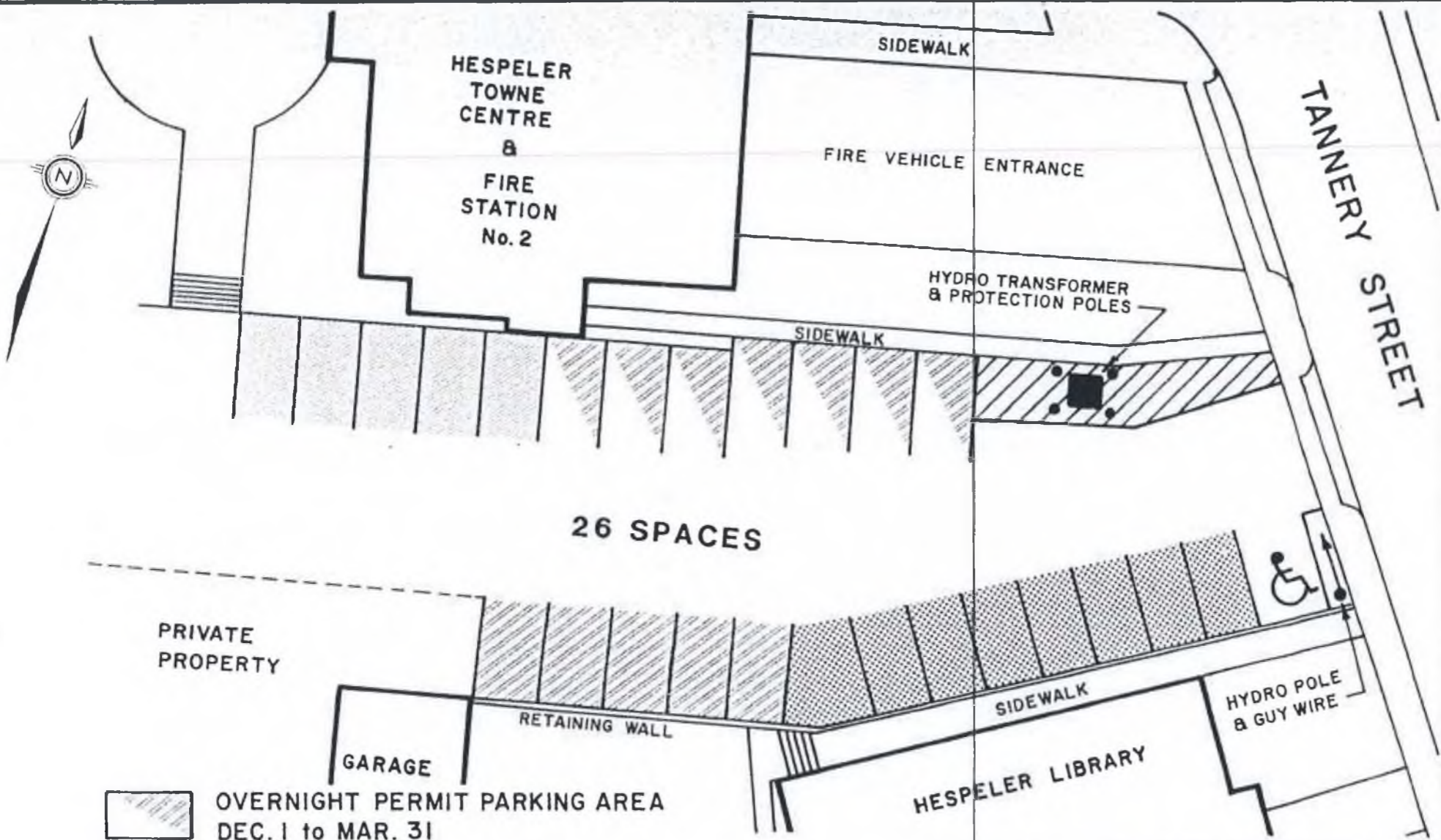

-  OVERNIGHT PERMIT PARKING AREA
DEC. 1 to MAR. 31
-  2 HOUR DISABLED PARKING
Mon. to Sat., 9:00a.m. - 6:00p.m.
-  2 HOUR FREE PARKING
Mon. to Sat., 9:00a.m. - 6:00p.m.
-  12 HOUR FREE PARKING
Mon. to Sat., 9:00a.m. - 6:00p.m.
-  PERMIT PARKING
FIRE DEPARTMENT EMPLOYEES

FIREHALL LOT (HESPELER)			
NO.	REVISIONS	BY	DATE
Drawn by: J. CURRIE		NOT TO SCALE	
Checked by: D.M.		Jard No.	
Date: AUGUST 12, 1993		TR-148A	

42

ATTACHED TO AND FORMING PART OF BY-LAW 186-06

P2

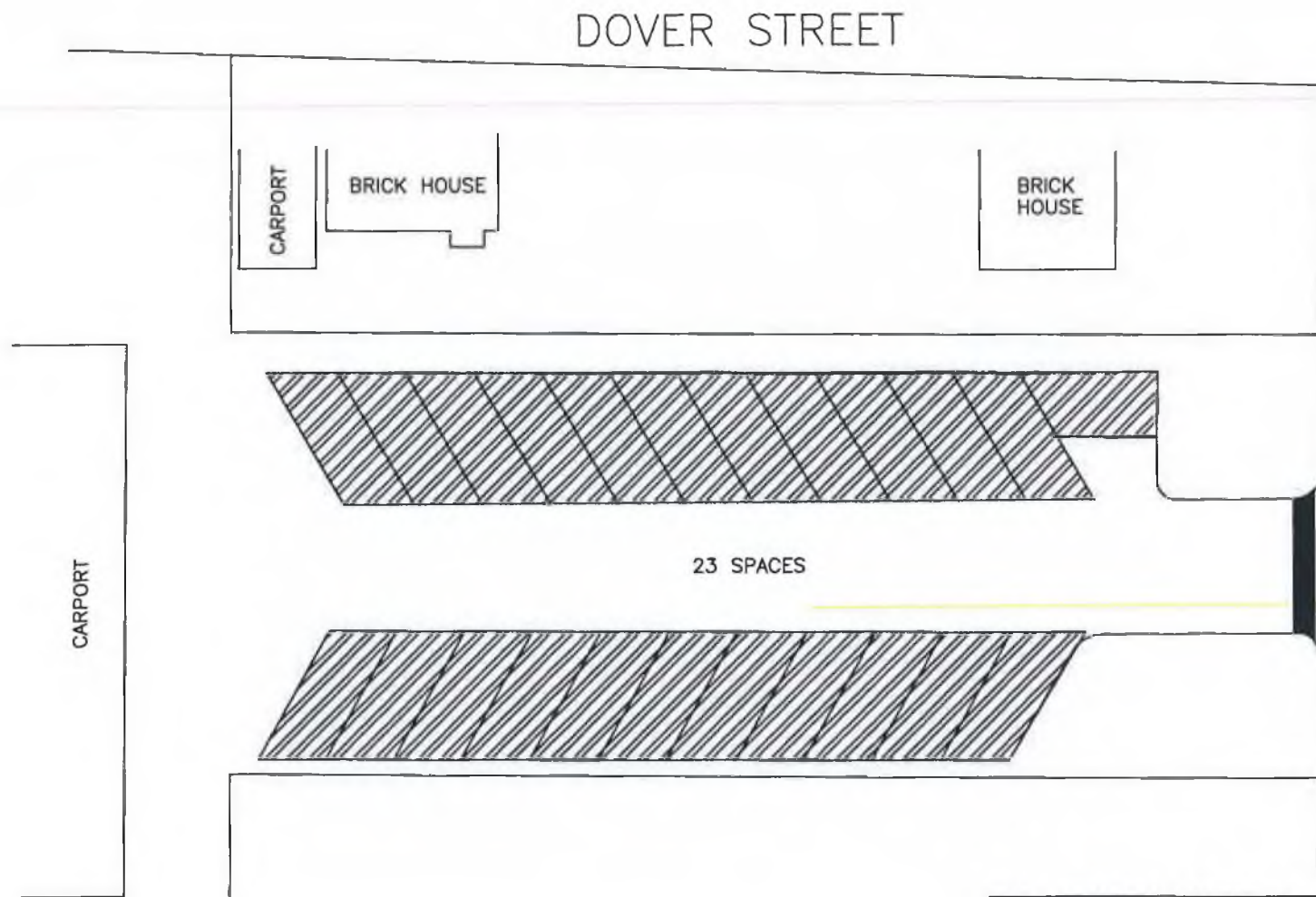

Legend:



Permit Parking
Mon.-Sat. 9:00a.m.-6:00p.m.

Title FIREHALL LOT (Preston) -23 Spaces-			
No.		By	Date
1.	Revised Reserved to Permit Parking	HD	June 2006
Drawn By: Kim Thomas		Not To Scale	
Checked By: Dave Maidment		TR-146	
Date: July, 2001			

G9

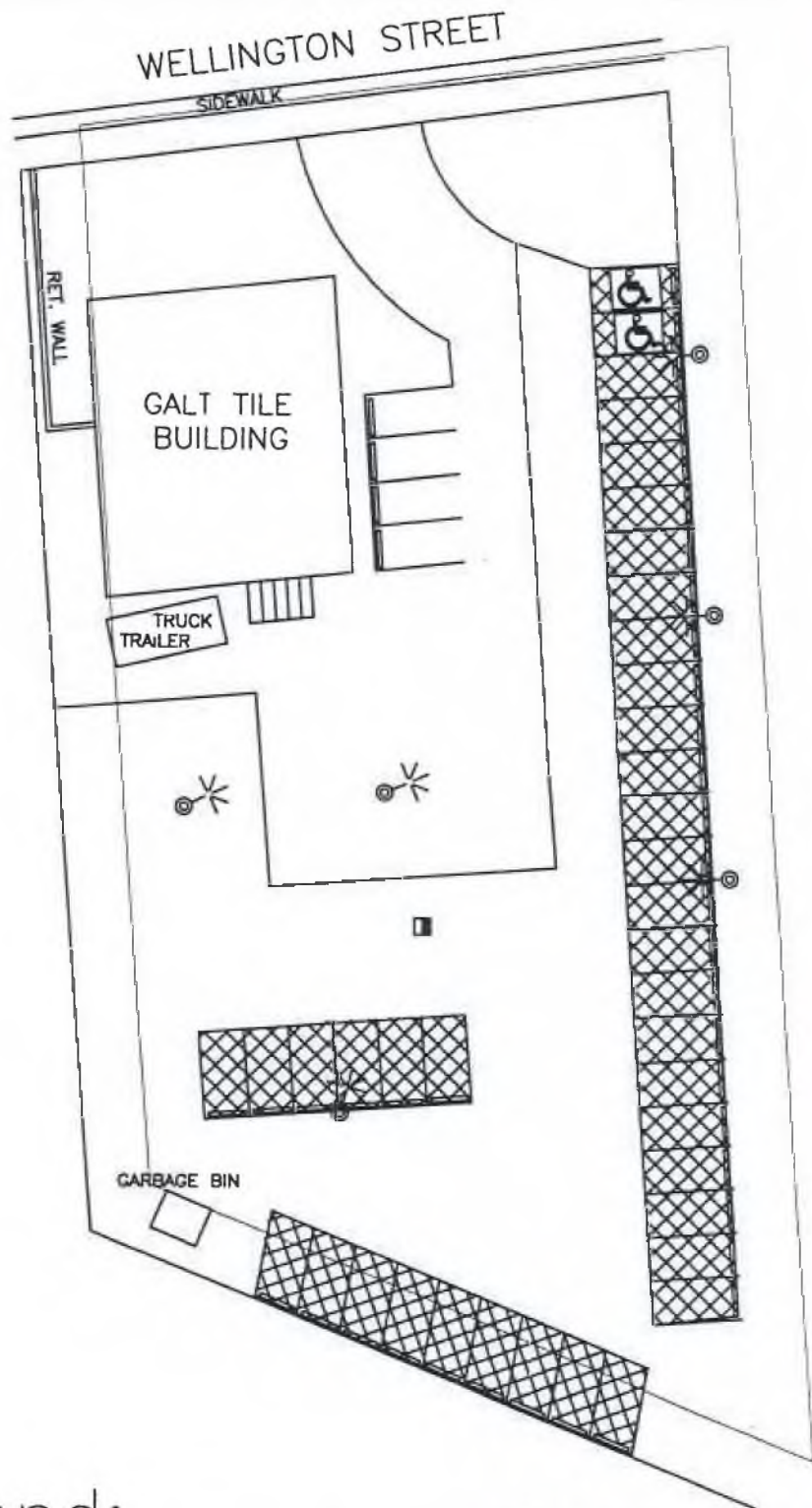

Legend:



Handicap Parking



Permit Parking
David Durward Centre

WELLINGTON STREET GALT TILE PARKING LOT			
No.	Revisions	By	Date
2.	Disabled & Permit Parking added	HD	August, 2006
1.	Area of parking lot added	KT	July, 2001
Drawn By: Kim Thomas		Scale : 1:500	
Checked By: G. Forhan		TR-256	
Date: Oct, 2000			

ATTACHED TO AND FORMING PART OF BY-LAW 186-06

615

LEGEND

-  DISABLED PARKING
PAY AND DISPLAY FEES APPLICABLE
-  PAY AND DISPLAY PARKING
MONDAY TO SATURDAY 7:00AM TO 9:00 PM
RATE: 1st. 2 HOURS - FREE
OVER 2 HOURS - \$1.00 FOR EVERY HOUR MAX. \$5.00



GRAND AVENUE LOT
224 SPACES

No.	Revisions	By	Date

Drawn By: RTB Scale: Not to Scale

Checked By: D. Maidment

Date: Oct./2005

TR-319

ST. ANDREWS STREET

GLEBE STREET

GRAND AVENUE

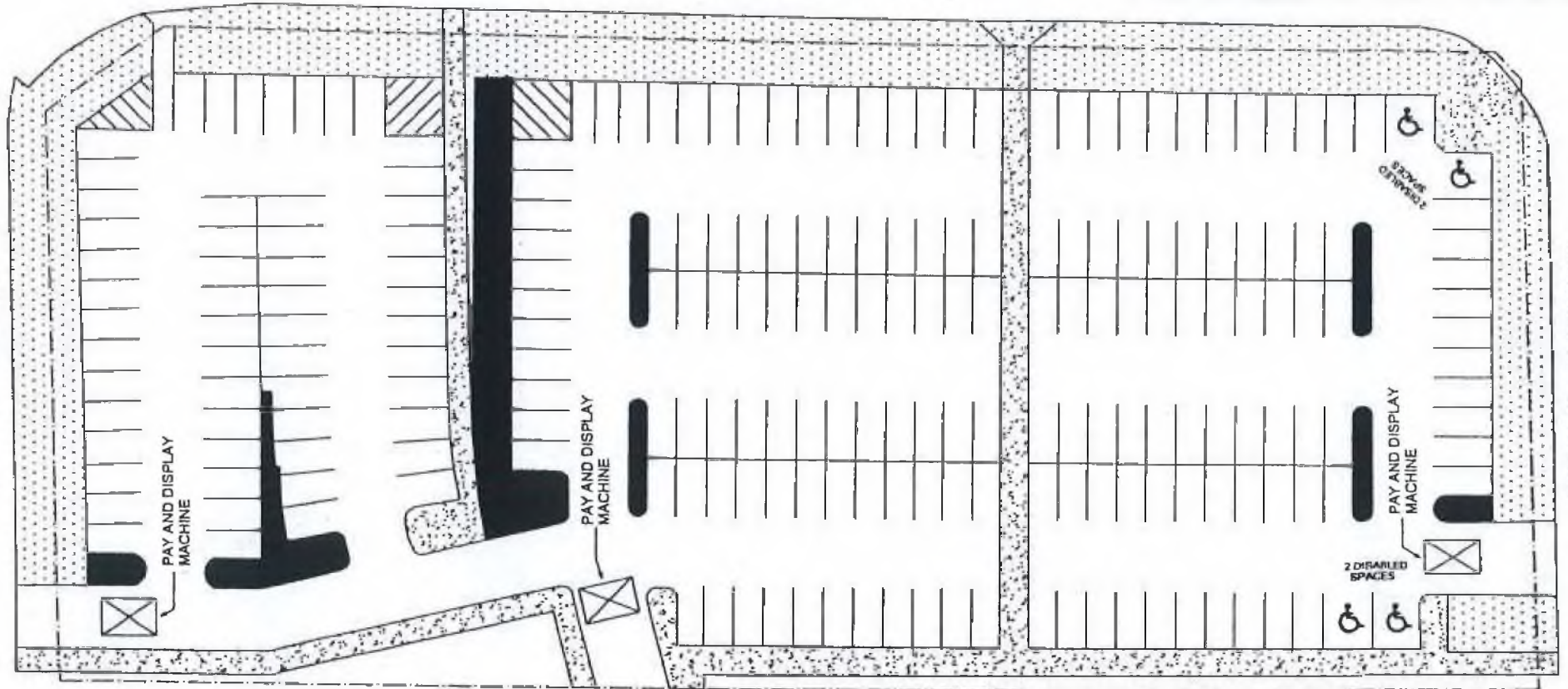

P2

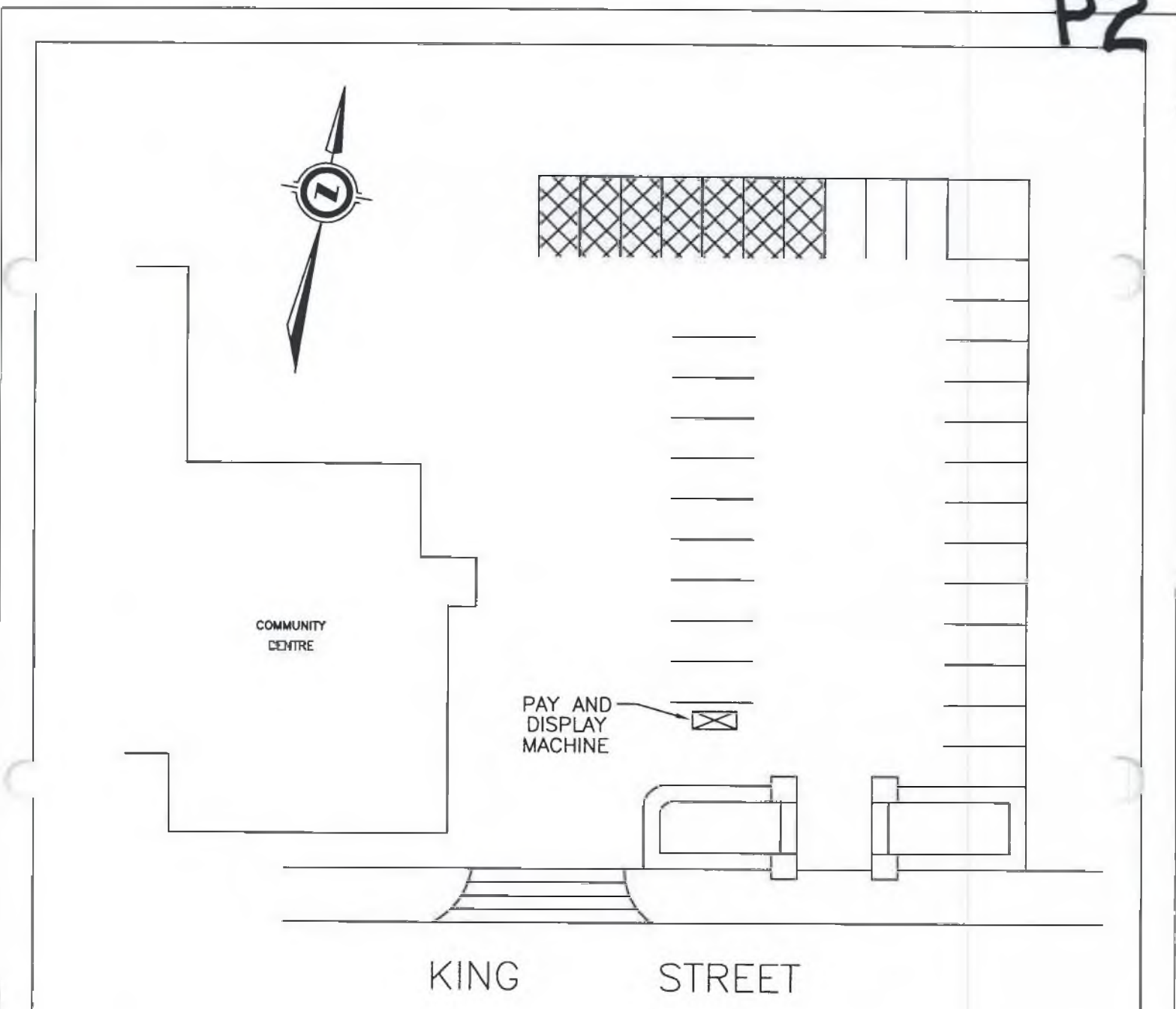

LEGEND:

 PERMIT PARKING (FIRE DEPT.)

PAY AND DISPLAY PARKING
MONDAY TO SATURDAY
7:00a.m. TO 9:00p.m.

RATES: 1st 2 HOURS—FREE
OVER 2 HOURS—\$1.00 FOR
EVERY HR. MAX. \$5.00

Title				KING STREET LOT			
No.	Revisions			By	Date		
1.	Permit Parking			HD	June 2006		
Drawn By: Kim Thomas				Scale : Not to Scale			
Checked By: D.Maidment				TR-161A			
Date: Jan., 2003							

ATTACHED TO AND FORMING PART OF BY-LAW 186-06

83

GEORGE STREET NORTH

GRAND AVENUE NORTH

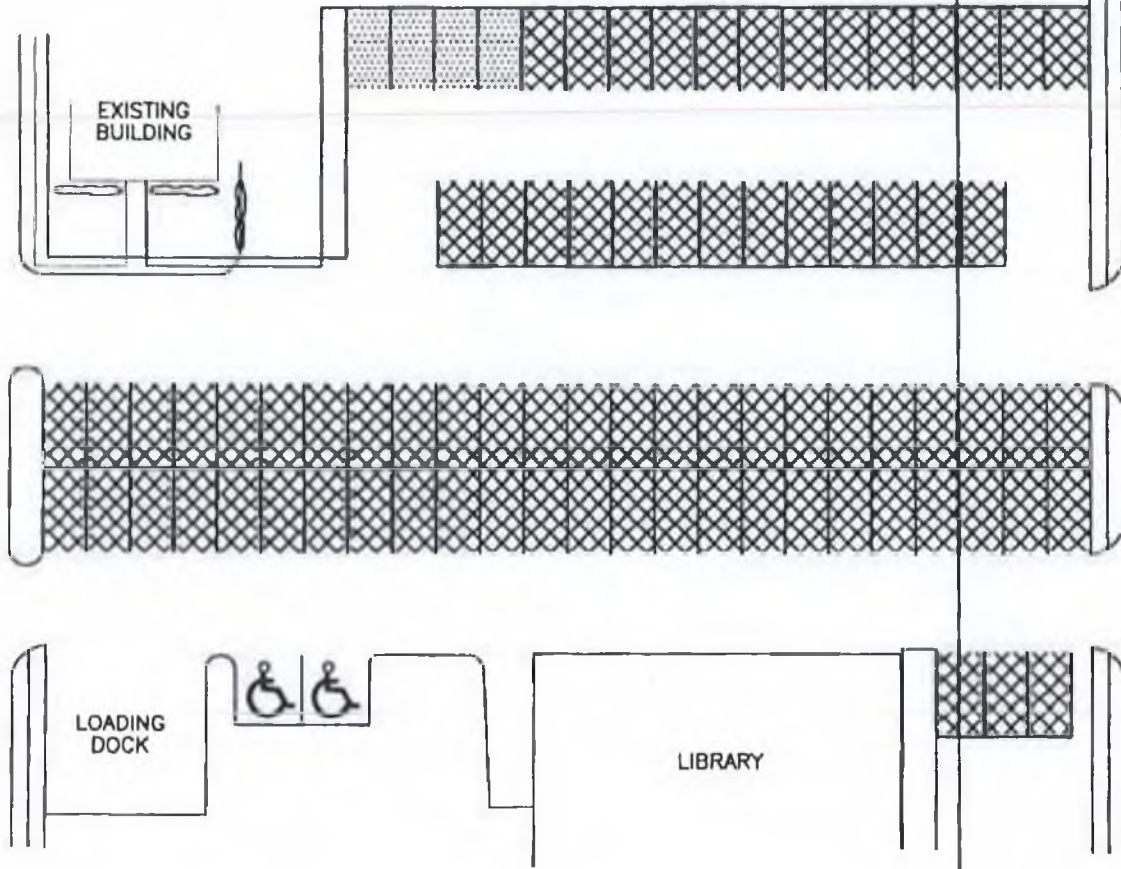

LEGEND:



DISABLED PARKING



PERMIT PARKING
MONDAY TO SATURDAY
9:00a.m. TO 6:00p.m.



2 HOURS FREE PARKING
MONDAY TO SATURDAY
9:00a.m. TO 6:00p.m.

NOTE: PERMIT PARKING IS NOT SPECIFICALLY ALLOCATED

Title		LIBRARY & GALLERY LOT 83 SPACES	
No.	Revisions	By	Date
1.	Permit Parking	HD	June 2006
Drawn By: Kim Thomas		Scale : Not to Scale	
Checked By: D.Maidment		TR-106A	
Date: Nov., 2005			

ATTACHED TO FORMING PART OF BY-LAW 186-06

MAIN STREET

WELLINGTON STREET

LUTZ STREET

LEGEND



DISABLED PARKING
2 HOURS FREE PARKING
MON. TO SAT.
9:00a.m. TO 6:00p.m.

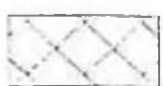

2 HOURS FREE PARKING
MON. TO SAT.
9:00a.m. TO 6:00p.m.



Title		MAIN ST. LOT	
		31 SPACES	
No.	Revisions	By	Date
Drawn By: Kim Thomas		Scale : Not to Scale	
Checked By: D.Maidment		TR-274	
Date: Dec., 2002			

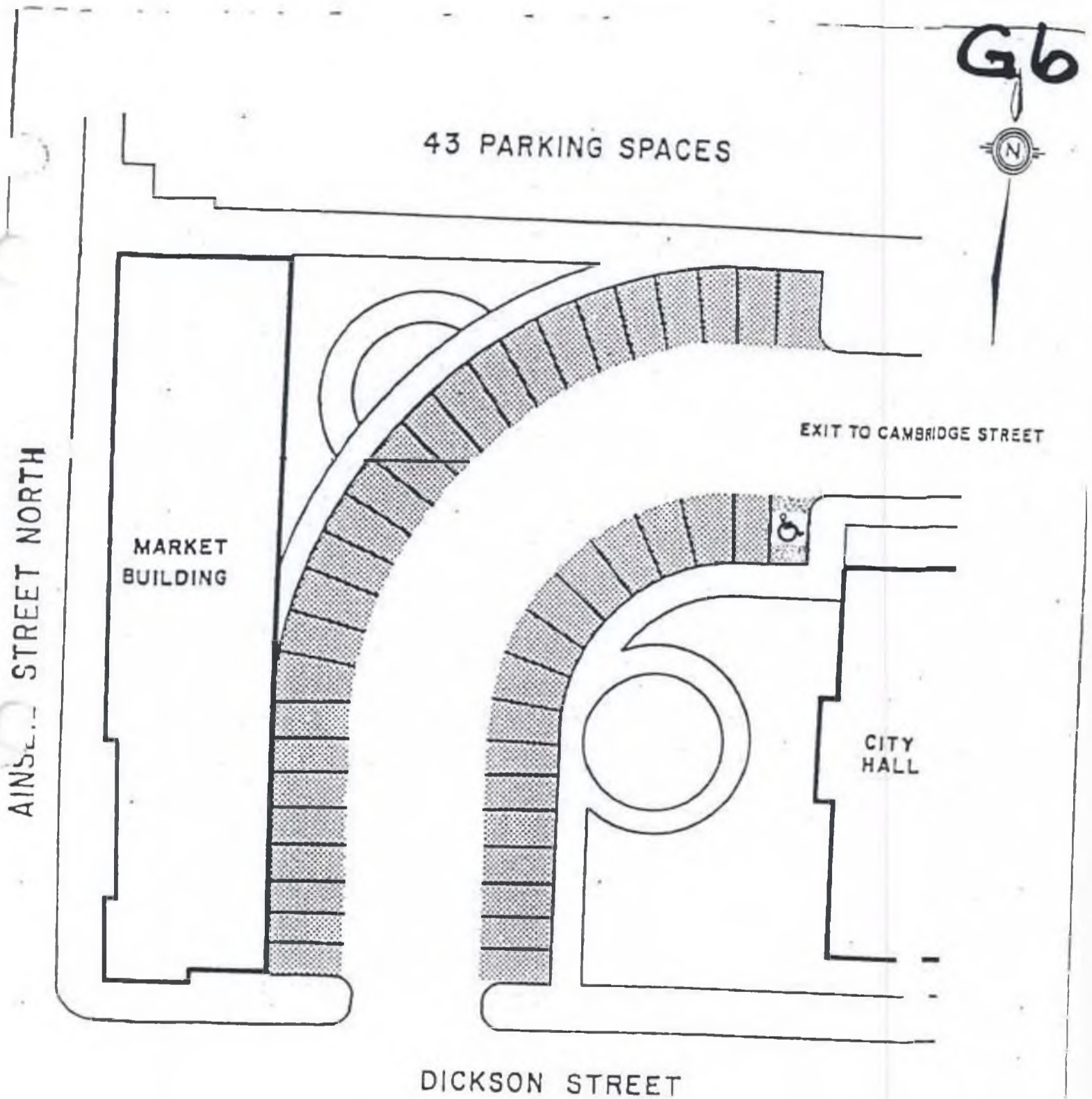

LEGEND:

 2 HOURS FREE PARKING
MON.-SAT. 9:00 a.m. - 6:00 p.m.

 DISABLED PARKING

MARKET SQUARE LOT			
NO.	REVISIONS	BY	DATE
1.	DISABLED PARKING	HD	2006
Drawn by: J. CURRIE		NOT TO SCALE	

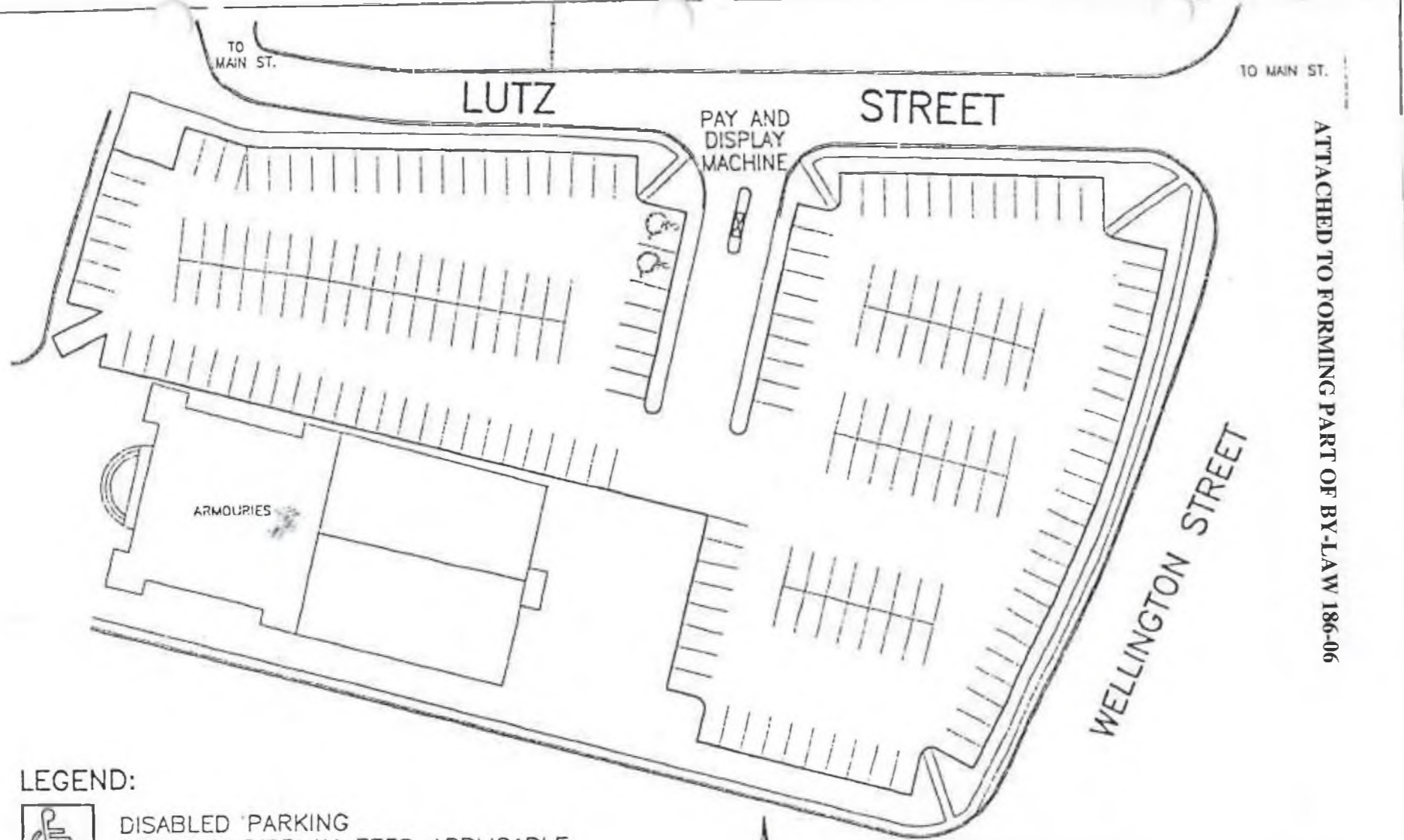

ATTACHED TO FORMING PART OF BY-LAW 186-06

LEGEND:



DISABLED PARKING
PAY AND DISPLAY FEES APPLICABLE

PAY AND DISPLAY PARKING
MONDAY TO SATURDAY
7:00a.m. TO 9:00p.m.

RATES: 1st 2 HOURS—FREE
OVER 2 HOURS—\$1.00 FOR
EVERY HR. MAX. \$5.00



Title				MILL STREET LOT			
No.	Revisions		By	Date			
Drawn By: Kim Thomas				Scale : Not to Scale			
Checked By: D.Maldment				TR-109D			
Date: Jan., 2003							

GI

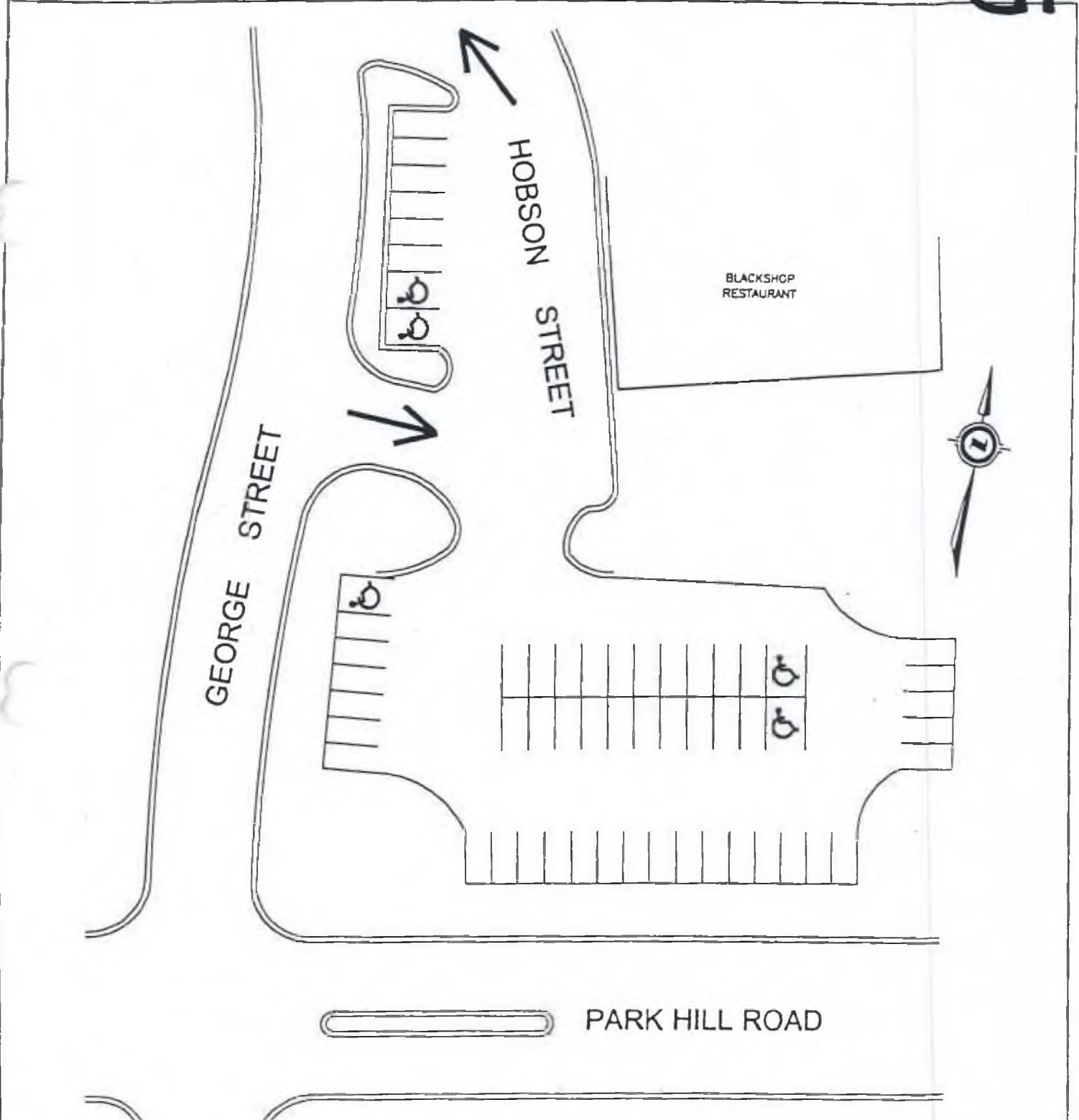

LEGEND:

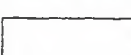
 - 12 HOURS FREE PARKING
MON. - SAT. 9:00a.m. - 6:00p.m.

 - DISABLED PARKING

Title		PARK HILL ROAD LOTS	
		57 SPACES	
No.	Revisions	By	Date
Drawn By: Kim Thomas		Scale : Not to Scale	
Checked By: D. Maidment		TR-110A	

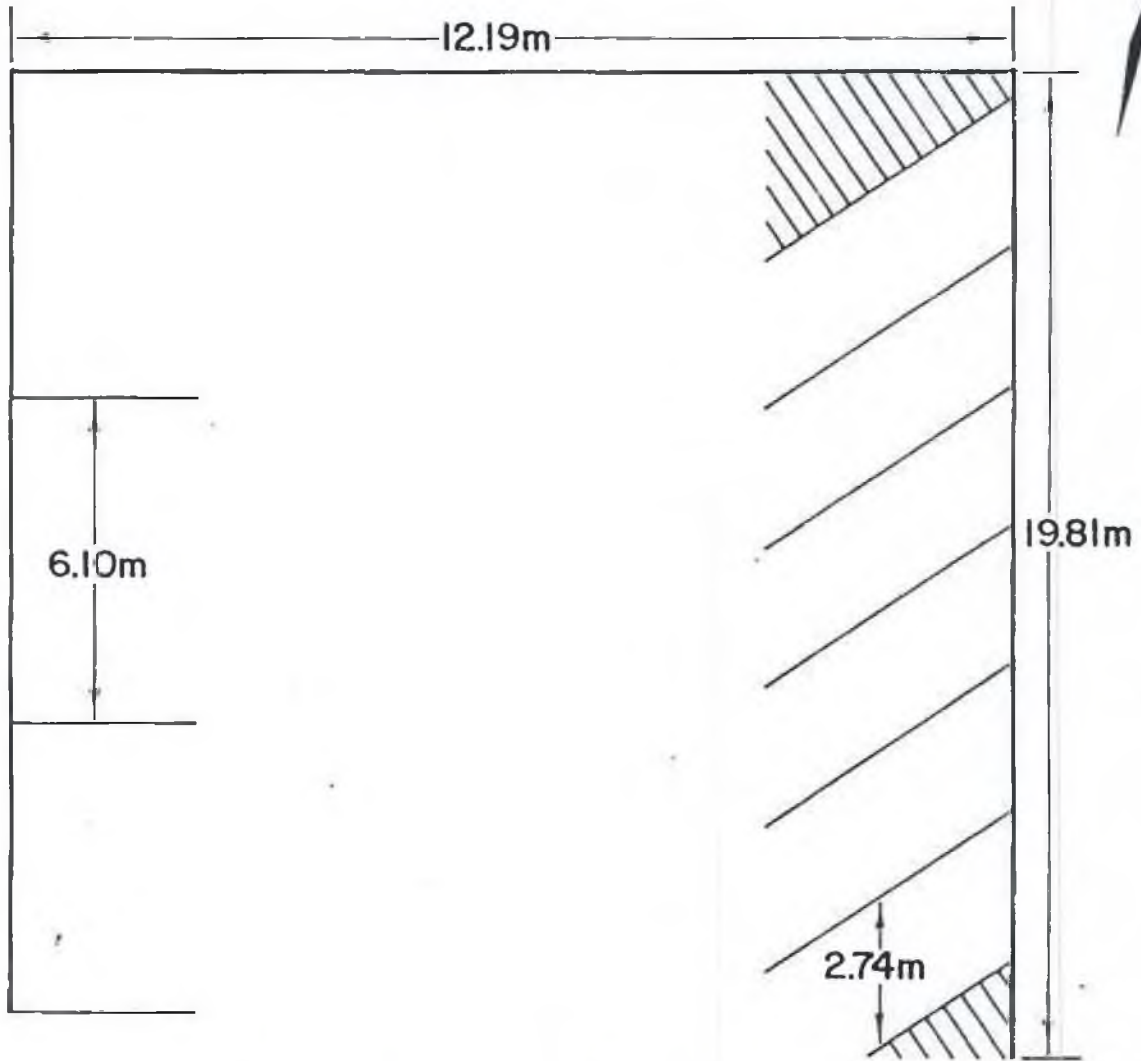

PARKVIEW

CRESCENT

24 HOUR FREE PARKING

PRESTON HEIGHTS LOT NO.1

NO.	REVISIONS	BY	DATE
Drawn by: KIM YOST		NOT TO SCALE	
Checked by:		Standard No.	
Date: AUG., 1988		TR-163	

SCHEDULE "B" TO BY-LAW NO. 62

PARKVIEW

CRESCENT

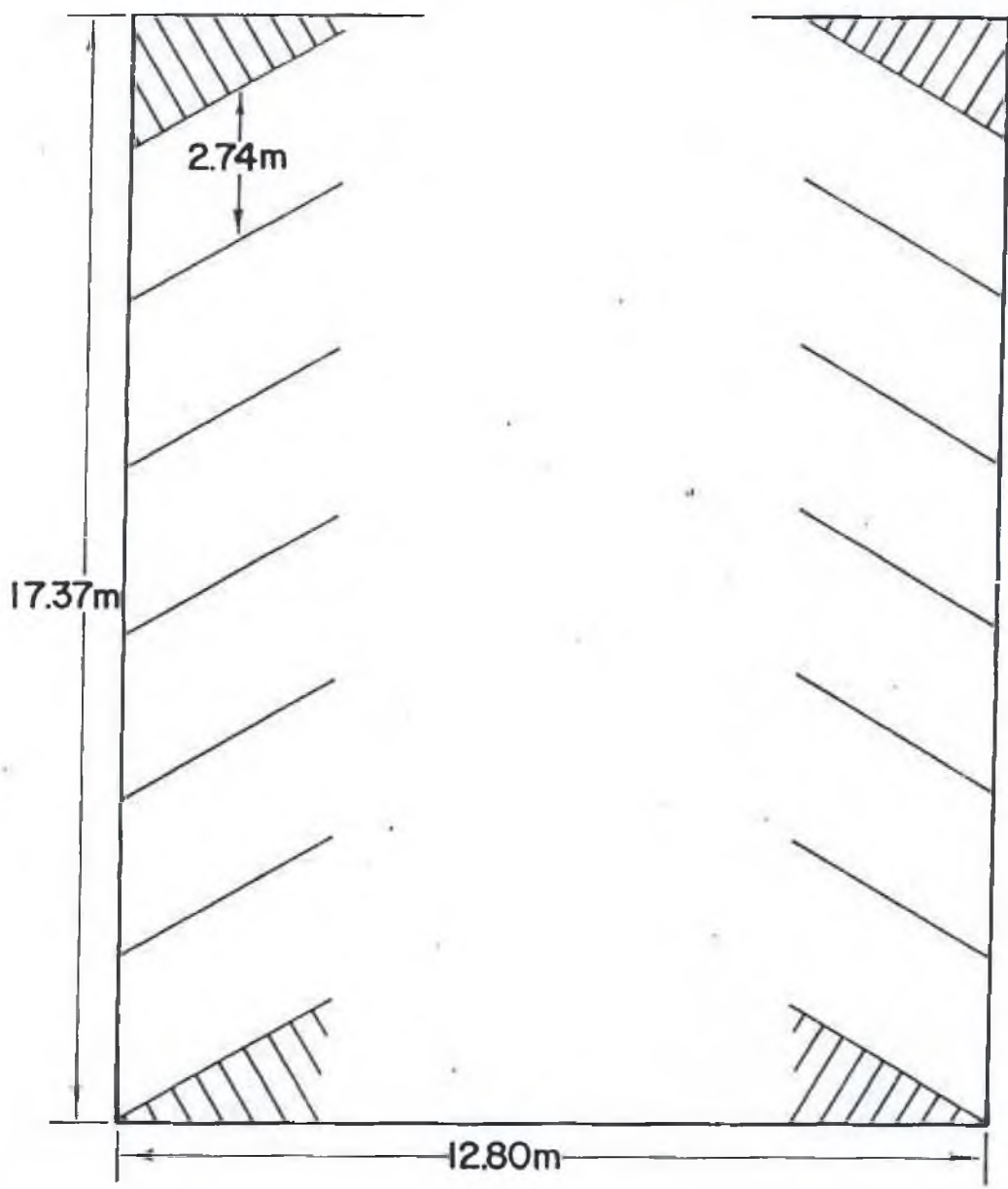

24 HOUR FREE PARKING

PRESTON HEIGHTS LOT NO.2

NO.	REVISIONS	BY	DATE
Drawn by: KIM YOST		NOT TO SCALE	
Checked by:		Standard No.	
Date: AUG.,1988		TR-164	

SCHEDULE "B" TO BY-LAW NO. 62

ATTACHED TO FORMING PART OF BY-LAW 186-06

PARKVIEW

CRESCENT

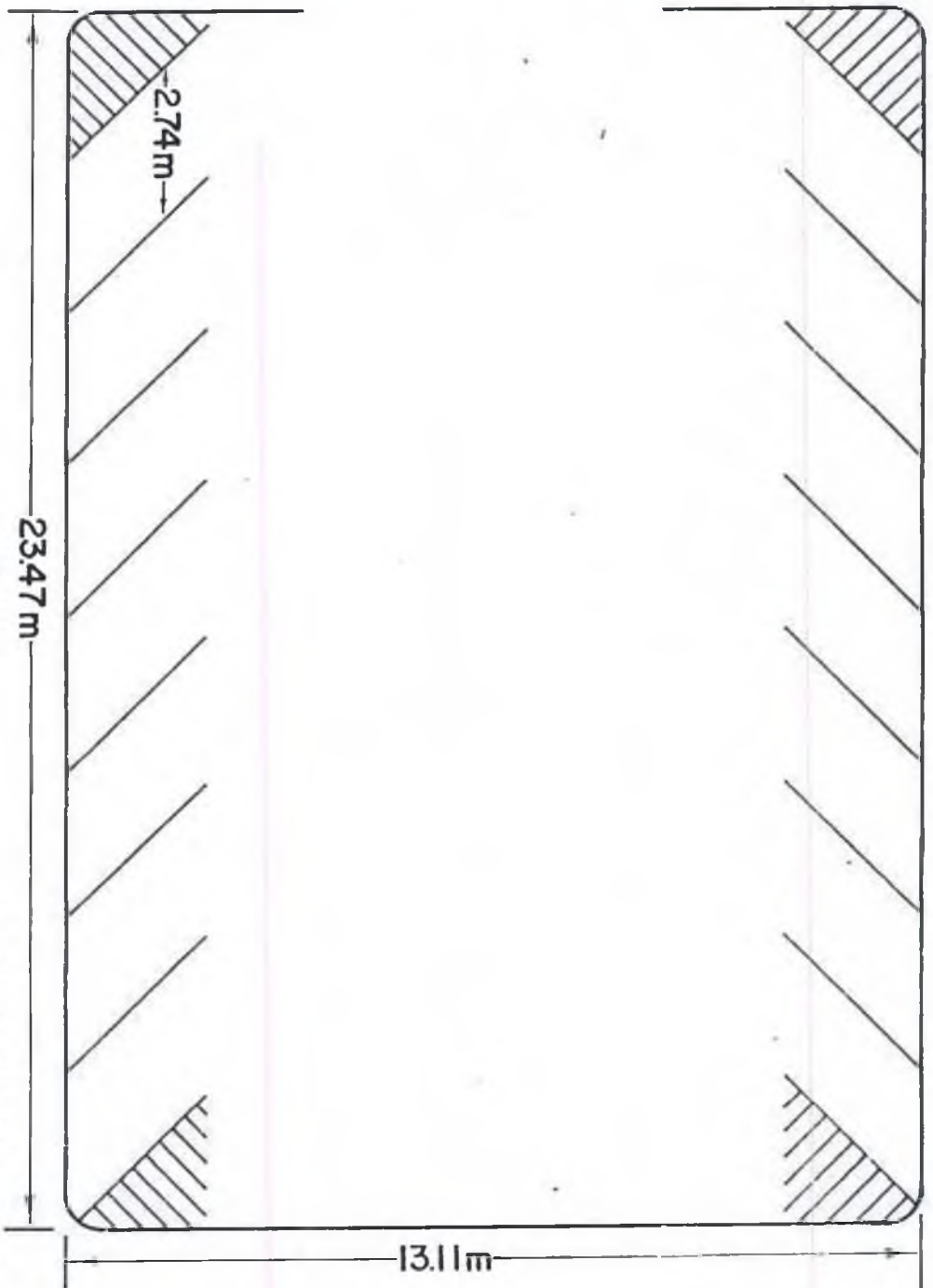

24 HOUR FREE PARKING

PRESTON HEIGHTS LOT NO. 3

NO.	REVISIONS	BY	DATE

Drawn by: KIM YOST NOT TO SCALE

Checked by: [Signature] :d No.

Date: AUG., 1988

TR-165



SCHEDULE "B" TO BY-LAW NO. 62

ATTACHED TO FORMING PART OF BY-LAW 186-06

PARKVIEW CRESCENT

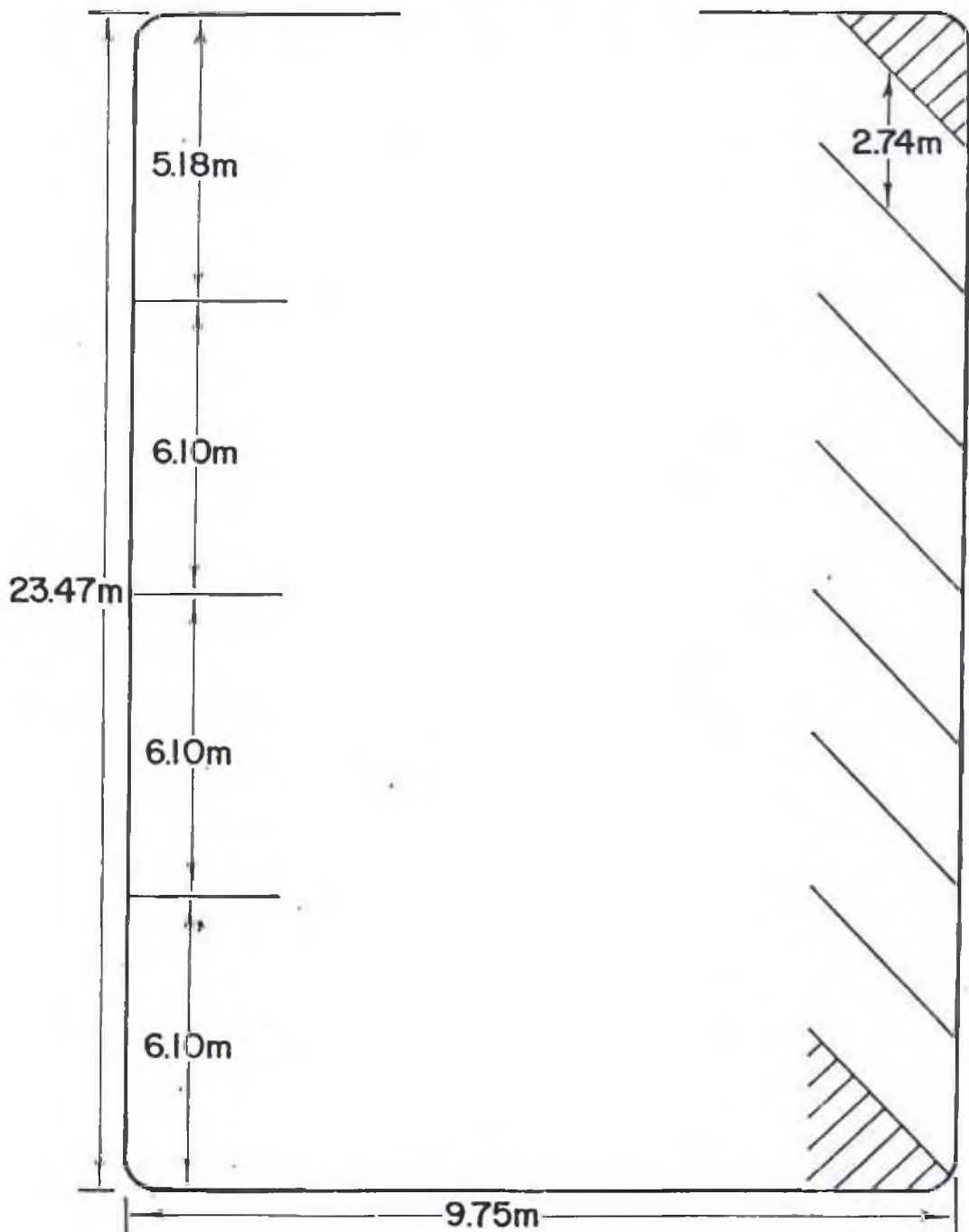

24 HOUR FREE PARKING

PRESTON HEIGHTS LOT NO.4

NO.	REVISIONS	BY	DATE
Drawn by: KIM YOST		NOT TO SCALE	
Checked by:		Standard No.	
Date: AUG., 1988		TR-166	

SCHEDULE "B" TO BY-LAW NO. 62

ATTACHED TO FORMING PART OF BY-LAW 186-06

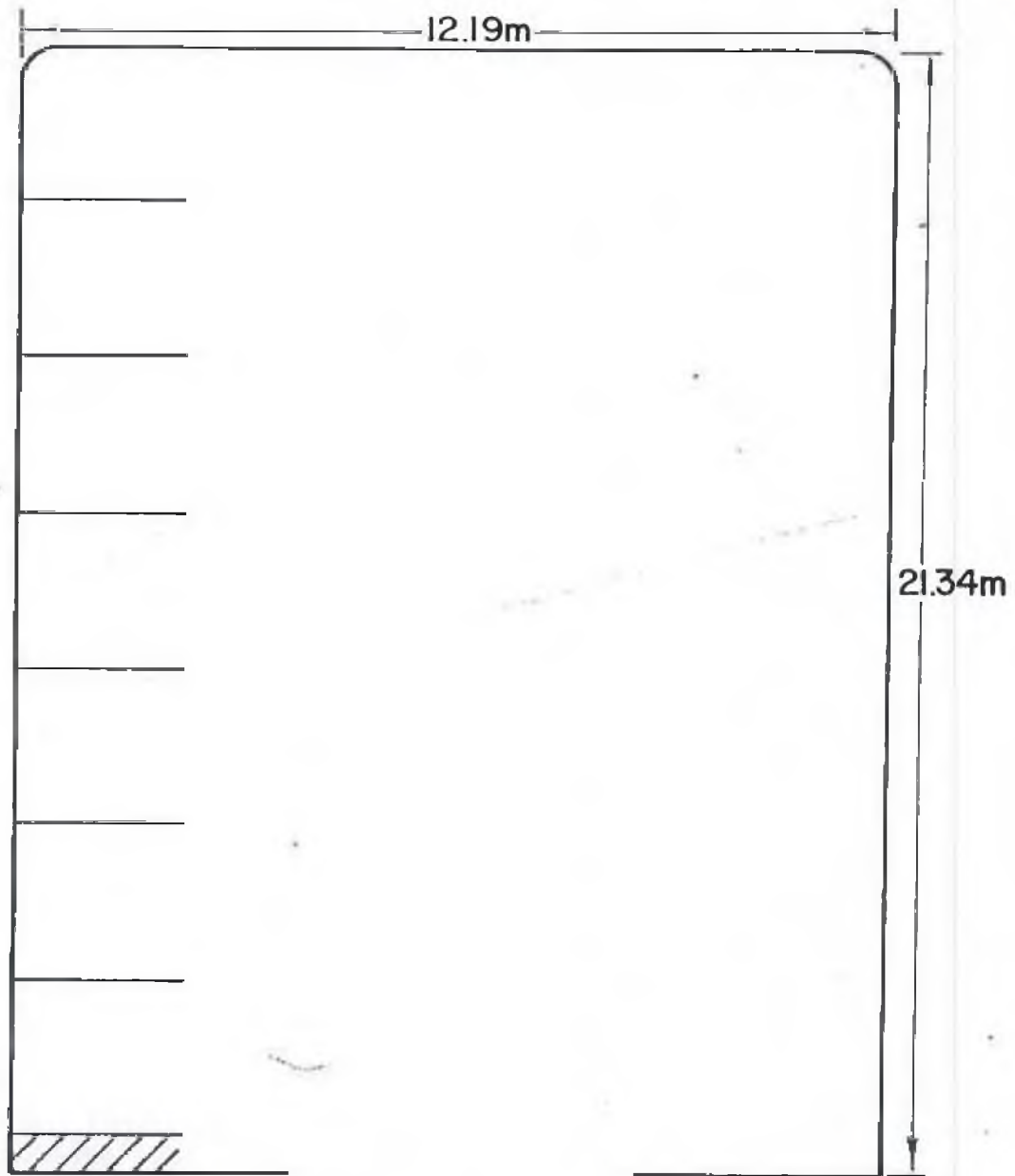

HILLVIEW ROAD

24 HOUR FREE PARKING

PRESTON HEIGHTS LOT NO.5

NO.	REVISIONS	BY	DATE
Drawn by: KIM YOST		NOT TO SCALE	
Checked by:		Standard No.	
Date: AUG.,1988		TR-167	

SCHEDULE "B" TO BY-LAW NO. 62

ATTACHED TO FORMING PART OF BY-LAW 186-06

PS

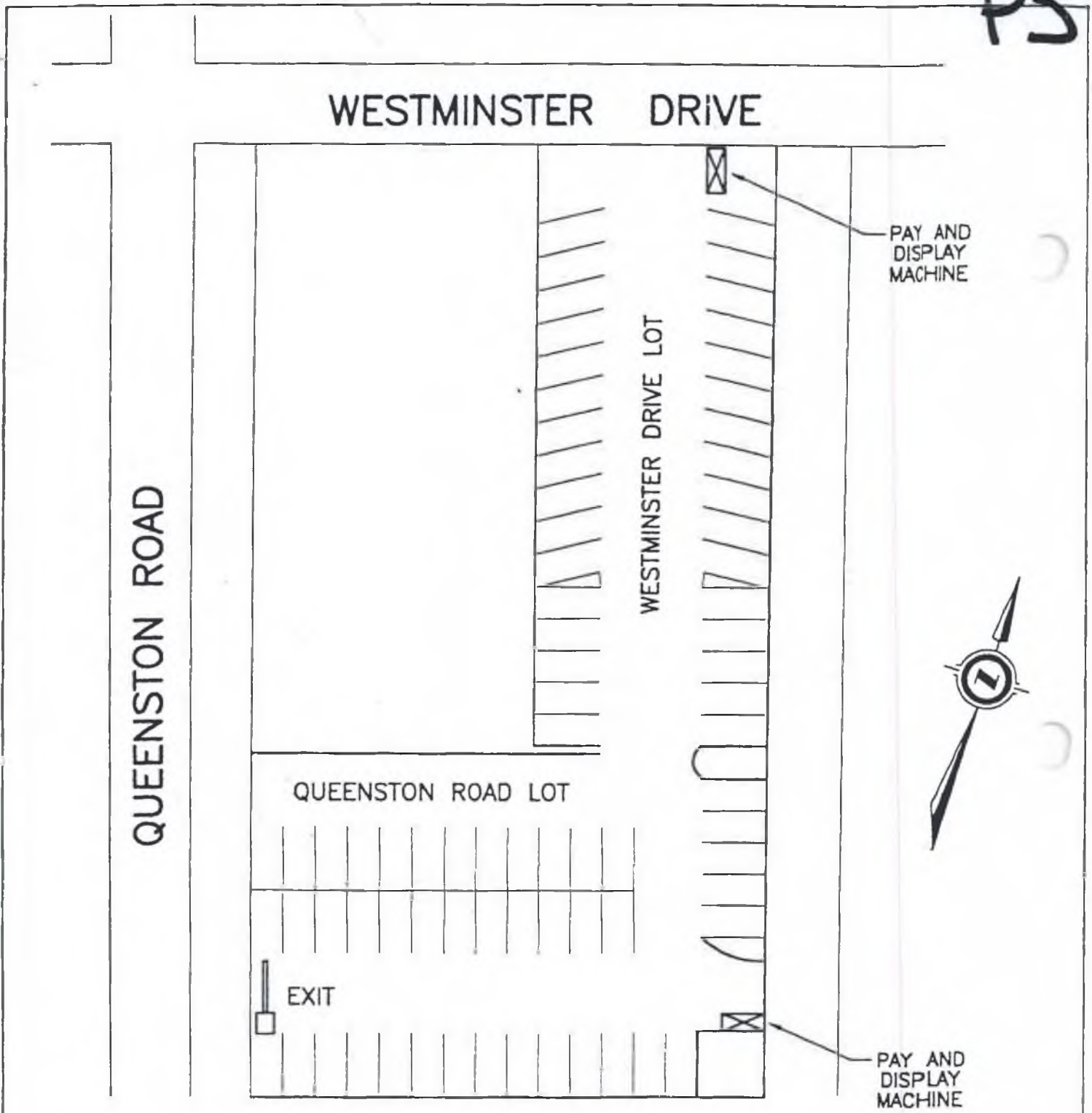

LEGEND:

PAY AND DISPLAY PARKING
 MONDAY TO SATURDAY
 7:00a.m. TO 9:00p.m.

RATES: 1st 2 HOURS—FREE
 OVER 2 HOURS—\$1.00 FOR
 EVERY HR. MAX. \$5.00

Title				QUEENSTON RD.& WESTMINSTER DR. LOT			
No.	Revisions		By	Date			
Drawn By: Kim Thomas				Scale : Not to Scale			
Checked By: D.Maidment				TR-160A			
Date: Jan., 2003							

44

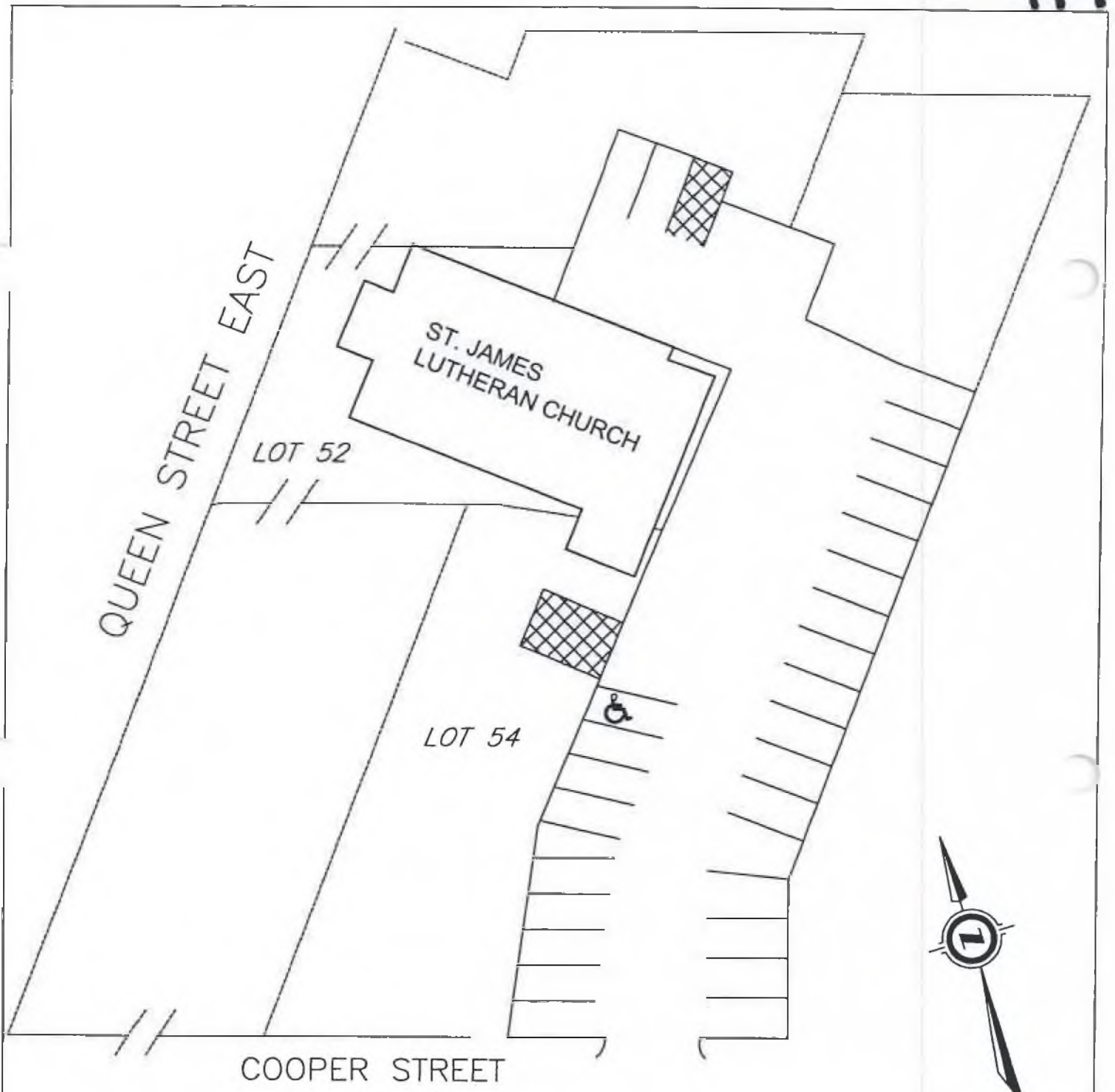

LEGEND:



DISABLED PARKING



12 HOURS FREE PARKING
MON.-SAT., 9:00a.m.-6:00p.m.



PERMIT PARKING
MON.-SAT., 9:00a.m.-6:00p.m.

Title				ST. JAMES CHURCH LOT	
				30 SPACES	
No.		By	Date		
1.	PERMIT PARKING	HD	JUNE 2006		
Drawn By: Kim Thomas		Scale : Not to Scale			
Checked By: D.Maidment		TR-124			
Date: Jan., 2003					

67

- THORNE STREET LOT -
20 SPACES



CAMBRIDGE STREET

LANEWAY

THORNE STREET

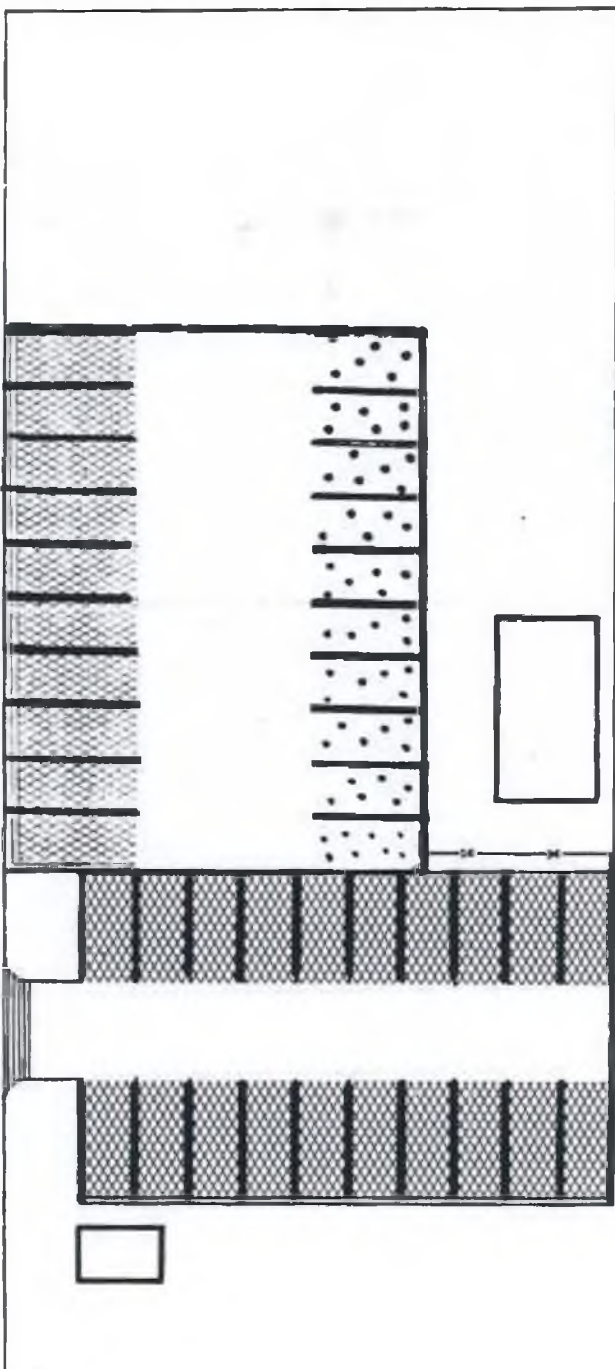

LEGEND



PERMIT PARKING
MON. - SAT. 9:00 a.m. - 6:00 p.m.



2 HOURS FREE PARKING
MON-SAT 9:00 am - 6:00 pm

WATER STREET LOT # 1

90 SPACES

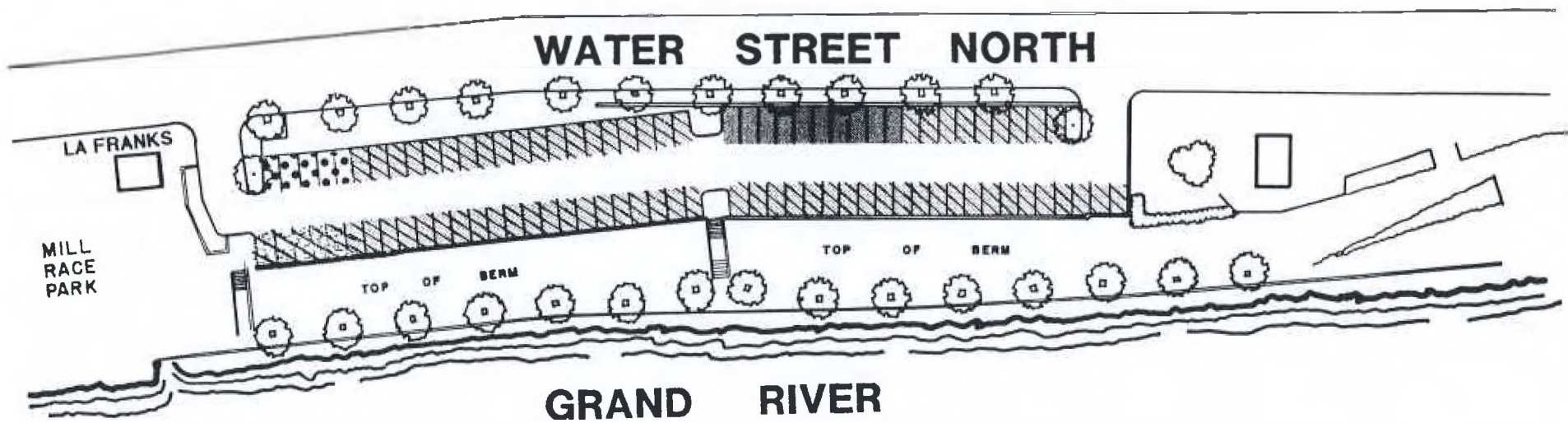

LEGEND

- PERMIT PARKING
MON.-FRI. 9:00a.m. - 6:00p.m.
- 2 HOURS FREE PARKING
SAT. 9:00a.m.-6:00p.m.
- 5 HOUR METERED PARKING
MON.-SAT. 9:00a.m. - 6:00p.m.
- 1 HOUR FREE PARKING
MON.-SAT. 9:00a.m. - 6:00p.m.
May 1 to Sept. 30

ATTACHED TO AND FORMING PART OF BY-LAW 186-06

62
TR-111A

G12

WATER STREET SOUTH

MAIN STREET

EXISTING BUILDINGS

AINSLIE STREET SOUTH

PAY AND DISPLAY MACHINE

PAY AND DISPLAY MACHINE

EXISTING BUILDING

EXISTING BUILDING

EXISTING BUILDING

LEGEND:



DISABLED PARKING
PAY AND DISPLAY FEES APPLICABLE

PAY AND DISPLAY PARKING
MONDAY TO SATURDAY
7:00a.m. TO 9:00p.m.

RATES: 1st 2 HOURS—FREE
OVER 2 HOURS—\$1.00 FOR
EVERY HR. MAX. \$5.00



Title				WATER STREET LOT #2			
No.	Revisions			By	Date		
1.	Disabled Parking Spaces			K.T.	Nov., 2005		
Drawn By: Kim Thomas				Scale : Not to Scale			
Checked By: D.Maidment				TR-112C			
Date: Jan., 2003							

**SCHEDULE 'C' TO BY-LAW NO.62
OF
THE CORPORATION OF THE CITY OF CAMBRIDGE**

Adam Street Lot	THAT part of Adam Street Lot regulated by a 2 hour maximum time limit Monday to Saturday 9:00 a.m. to 6:00 p.m.	FREE
	THAT part of Adam Street Lot regulated by a 24 hour maximum time limit permit for parking Monday to Sunday	FREE
	THAT part of Adam Street Lot regulated by a 12 hour maximum time limit Monday to Saturday 9:00 a.m. to 9:00 p.m.	FREE
Ainslie Street Lot	THAT part of Ainslie Street Lot regulated by 12 hour maximum time limit Monday to Saturday 9:00 a.m. to 9:00 p.m.	FREE
	THAT part of Ainslie Street Lot regulated by a 12 hour maximum time limit Disabled Parking Monday to Saturday 9:00 a.m. to 9:00 p.m.	FREE
	THAT part of Ainslie Street Lot regulated as Permit Parking for Hubbard Brothers Customers only Monday to Saturday 9:00 a.m. to 9:00 p.m.	FREE
Argyle Street Lot	THAT part of Argyle Street Lot be regulated by Permit Parking Monday to Saturday 9:00 a.m. to 6:00 p.m.	AS PER THE CITY'S RATE REVIEW
	THAT part of Argyle Street Lot regulated by a 2 hour maximum time limit Monday to Saturday 9:00 a.m. to 6:00 p.m.	FREE
	THAT part of Argyle Street Lot regulated by a 2 hour maximum time limit Disabled Parking Monday to Saturday 9:00 a.m. to 6:00 p.m.	FREE
Barradell's Loft	THAT part of Barradell's Lot regulated by a 12 hour maximum time limit Monday to Saturday	FREE
Beverly Street Lot	THAT part of the Beverly Street Lot regulated by 12 hour maximum time limit Monday to Saturday 9:00 a.m. to 9:00 p.m.	FREE
Cambridge Place	THAT part of Cambridge Place regulated by Permit Parking Monday to Friday 9:00 a.m. to 6:00 p.m.	FREE
	THAT part of Cambridge Place regulated by a 2 hour maximum time limit Monday to Saturday 9:00 a.m. to 6:00 p.m.	FREE

**SCHEDULE 'C' TO BY-LAW NO.62
OF
THE CORPORATION OF THE CITY OF CAMBRIDGE**

	THAT part of Cambridge Place regulated by a 1 hour maximum time limit Monday to Saturday 9:00 a.m. to 6:00 p.m.	FREE
	THAT part of Cambridge Place regulated by a 2 hour maximum time limit Disabled Parking Monday to Saturday 9:00 a.m. to 6:00 p.m.	FREE
	THAT part of Cambridge Place regulated by City of Cambridge Employee Parking "30 minutes"	FREE
Cambridge Civic Square	THAT part of Cambridge Civic Square Lot regulated by 24 Hour Permit Parking Monday to Sunday	AS PER THE CITY'S RATE REVIEW
	THAT part of Cambridge Civic Square Lot regulated by a 2 hour maximum time limit Monday to Saturday 9:00 a.m. to 6:00 p.m.	FREE
	THAT part of Cambridge Civic Square Lot regulated by Permit Parking Monday to Friday 9:00 a.m. to 6:00 p.m.	AS PER THE CITY'S RATE REVIEW
	THAT part of Cambridge Civic Square Lot regulated by Permit Parking Monday to Saturday 9:00 a.m. to 6:00 p.m.	FREE
	THAT part of Cambridge Civic Square Lot regulated by a 2 hour maximum time limit Disabled Parking Monday to Saturday 9:00 a.m. to 6:00 p.m.	FREE
Dickson Street Lot	THAT part of Dickson Street Lot regulated by Permit Parking Monday to Saturday 9:00 a.m. to 6:00 p.m.	AS PER THE CITY'S RATE REVIEW
	THAT part of Dickson Street Lot regulated by a 2 hour maximum time limit Monday to Saturday 9:00 a.m. to 6:00 p.m.	FREE
	THAT part of Dickson Street Lot regulated by a 2 hour maximum time limit Disabled Parking Monday to Saturday 9:00 a.m. to 6:00 p.m.	FREE
	THAT part of Dickson Street Lot regulated by a 1 hour maximum time limit Monday to Saturday 9:00 a.m. to 6:00 p.m.	FREE
Dover Street Lot	THAT part of the Dover Street Lot regulated by a 12 hour maximum time limit Monday to Saturday 9:00 a.m. to 9:00 p.m.	FREE
Duke Street Lot	THAT part of Duke Street Lot regulated by Permit Parking Monday to Saturday 9:00 a.m. to 6:00 p.m.	AS PER THE CITY'S RATE REVIEW

**SCHEDULE 'C' TO BY-LAW NO.62
OF
THE CORPORATION OF THE CITY OF CAMBRIDGE**

	THAT part of Duke Street Lot regulated by a 2 hour maximum time limit Monday to Saturday 9:00 a.m. to 6:00 p.m.	FREE
Fire Hall Lot (Hespeler)	THAT part of Fire Hall Lot regulated by a 24 hour maximum time limit Permit Parking Monday to Sunday 9:00 a.m. to 6:00 p.m.	FREE
	THAT part of Fire Hall Lot regulated by a 2 hour maximum time limit Disabled Parking Monday to Saturday 9:00 a.m. to 6:00 p.m.	FREE
	THAT part of Fire Hall Lot regulated by a 12 hour maximum time limit Monday to Saturday 9:00 a.m. to 6:00 p.m.	FREE
	THAT part of Fire Hall Lot regulated by a 2 hour maximum time limit Monday to Saturday 9:00 a.m. to 6:00 p.m.	FREE
	THAT part of Fire Hall Lot regulated by 24 Hour Permit parking Monday to Sunday	AS PER THE CITY'S RATE REVIEW
Fire Hall Lot (Preston)	THAT part of Fire Hall Lot regulated by Permit Parking Monday to Saturday 9:00 a.m. to 6:00 p.m.	AS PER THE CITY'S RATE REVIEW
	THAT part of Fire Hall Lot regulated as Permit Parking Monday to Saturday 9:00 a.m. to 6:00 p.m.	FREE
	THAT part of Fire Hall Lot regulated by a Pay and Display Operation <ul style="list-style-type: none"> - a 2 hour maximum time limit - over a 2 hour maximum time limit Monday to Saturday 7:00 a.m. to 9:00 p.m.	FREE \$1.00 for every hour, Max. \$5.00
Galt Tile Lot	THAT part of the Galt Tile Lot regulated by a 12 hour maximum time limit Saturday 9:00 a.m. to 9:00 p.m.	FREE
	THAT part of the Galt Tile Lot regulated by Permit Parking Monday to Friday 9:00 a.m. to 6:00 p.m.	FREE
Grand Avenue Lot	THAT part of the Grand Avenue Lot regulated by a Pay and Display Operation <ul style="list-style-type: none"> - a 2 hour maximum time limit - over a 2 hour maximum time limit Monday to Saturday 7:00 a.m. to 9:00 p.m.	FREE \$1.00 for every hour, Max. \$5.00

**SCHEDULE 'C' TO BY-LAW NO.62
OF
THE CORPORATION OF THE CITY OF CAMBRIDGE**

	THAT part of the Grand Avenue Lot regulated by Disabled Parking Monday to Saturday 7:00 a.m. to 9:00 p.m.	Pay & Display Fees
	THAT part of the Grand Avenue Lot regulated by 24 hour Permit Parking Monday to Sunday	AS PER THE CITY'S RATE REVIEW
King Street Lot	THAT part of King Street Lot regulated by Permit Parking Monday to Saturday 9:00 a.m. to 6:00 p.m.	AS PER THE CITY'S RATE REVIEW
	THAT part of King Street Lot regulated by Permit Parking for Fire Department Employees	FREE
	THAT part of King Street Lot regulated by a Pay and Display Operation <ul style="list-style-type: none"> - a 2 hour maximum time limit - over a 2 hour maximum time limit Monday to Saturday 7:00 a.m. to 9:00 p.m.	FREE \$1.00 for every hour, Max. \$5.00
Library & Gallery Lot	THAT part of Library & Gallery Lot regulated by a 2 hour maximum time limit Monday to Saturday 9:00 a.m. to 6:00 p.m.	FREE
	THAT part of Library & Gallery Lot regulated by Permit Parking Monday to Saturday	Per agreement with Library
	THAT part of Library & Gallery Lot regulated by a 2 hour maximum time limit Disabled Parking Monday to Saturday 9:00 a.m. to 6:00 p.m.	FREE
Main Street Lot	THAT part of Main Street Lot regulated by a 2 hour maximum time limit Monday to Saturday 9:00 a.m. to 6:00 p.m.	FREE
	THAT part of Main Street Lot regulated by a 2 hour maximum time limit Disabled Parking Monday to Saturday 9:00 a.m. to 6:00 p.m.	FREE
Market Square Lot	THAT part of Market Square Lot regulated by a 2 hour maximum time limit Monday to Saturday 9:00 a.m. to 6:00 p.m.	FREE
	THAT part of Market Square Lot regulated by No Parking Overnight between 2:30 a.m. to 6:00 a.m. at any time during the year	
	THAT part of Market Square Lot regulated by a 2 hour maximum time limit Disabled Parking Monday to Saturday 9:00 a.m. to 6:00 p.m.	FREE
Mill Street Lot	THAT part of Mill Street Lot regulated by a Pay and Display Operation <ul style="list-style-type: none"> - a 2 hour maximum time limit - over a 2hour maximum time limit Monday to Saturday	FREE \$1.00 for every hour, Max. \$5.00

**SCHEDULE 'C' TO BY-LAW NO.62
OF
THE CORPORATION OF THE CITY OF CAMBRIDGE**

	7:00 a.m. to 9:00 p.m.	
	THAT part of Mill Street Lot regulated by Permit Parking Monday to Saturday 9:00 a.m. to 6:00 p.m.	AS PER THE CITY'S RATE REVIEW
	THAT part of Mill Street Lot regulated by Disabled Parking Monday to Saturday 7:00 a.m. to 9:00 p.m.	Pay and Display Fees
Park Hill Road Lot	THAT part of Park Hill Road Lot regulated by a 12 hour maximum time limit Monday to Saturday 9:00 a.m. to 9:00 p.m.	FREE
	THAT part of Park Hill Road Lot regulated by a 12 hour maximum time limit Disabled Parking Monday to Saturday 9:00 a.m. to 9:00 p.m.	FREE
Preston Heights Lot #1	THAT part of Preston Heights Lot #1 regulated by a 24 hour maximum time limit Monday to Sunday	FREE
Preston Heights Lot #2	THAT part of Preston Heights Lot #2 regulated by a 24 hour maximum time limit Monday to Sunday	FREE
Preston Heights Lot #3	THAT part of Preston Heights Lot #3 regulated by a 24 hour maximum time limit Monday to Sunday	FREE
Preston Heights Lot #4	THAT part of Preston Heights Lot #4 regulated by a 24 hour maximum time limit Monday to Sunday	FREE
Preston Heights Lot #5	THAT part of Preston Heights Lot #5 regulated by a 24 hour maximum time limit Monday to Sunday	FREE
Queenston Road Lot	THAT part of Queenston Road Lot regulated by Permit Parking Monday to Friday 9:00 a.m. to 6:00 p.m.	AS PER THE CITY'S RATE REVIEW
	THAT part of Queenston Road Lot regulated by a Pay and Display Operation - a 2 hour maximum time limit - over a 2 hour maximum time limit Monday to Saturday 7:00 a.m. to 9:00 p.m.	FREE \$1.00 for every hour, Max. \$5.00
St. James Church Lot	THAT part of St. James Church Lot regulated by a 12 hour maximum time limit Monday to Saturday 9:00 a.m. to 6:00 p.m.	FREE
	THAT part of St. James Church Lot regulated as Permit Parking for Church members	FREE
Thorne Street Lot	THAT part of Thorne Street Lot regulated by Permit Parking Monday to Saturday 9:00 a.m. to 6:00 p.m.	FREE
	THAT part of Thorne Street Lot regulated by Permit Parking Monday to Saturday	AS PER THE CITY'S RATE REVIEW

**SCHEDULE 'C' TO BY-LAW NO.62
OF
THE CORPORATION OF THE CITY OF CAMBRIDGE**

	9:00 a.m. to 6:00 p.m.	
	THAT part of Thorne Street Lot regulated by a 2 hour maximum time limit Monday to Saturday 9:00 a.m. to 6:00 p.m.	FREE
Water Street Lot #1	THAT part of Water Street Lot #1 regulated by Permit Parking Monday to Friday 9:00 a.m. to 6:00 p.m.	AS PER THE CITY'S RATE REVIEW
	THAT part of Water Street Lot #1 regulated by Parking Meters Monday to Saturday 9:00 a.m. to 6:00 p.m.	50¢ / 60 minutes Maximum 5 hour limit
	THAT part of Water Street Lot #1 regulated by a 1 hour maximum time limit Monday to Saturday 9:00 a.m. to 6:00 p.m. May 1 to September 30	FREE
	THAT part of Water Street Lot #1 regulated by a 2 hour maximum time limit Saturdays 9:00 a.m. to 6:00 p.m.	FREE
	THAT part of Water Street Lot #1 regulated by 24 Hour Permit Parking Monday to Sunday	AS PER THE CITY'S RATE REVIEW
Water Street Lot #2	THAT part of Water Street Lot #2 regulated by Permit Parking Monday to Friday 9:00 a.m. to 6:00 p.m.	AS PER THE CITY'S RATE REVIEW
	THAT part of Water Street Lot #2 regulated by a Pay and Display Operation <ul style="list-style-type: none"> - a 2 hour maximum time limit - over a 2 hour maximum time limit Monday to Saturday 7:00 a.m. to 9:00 p.m.	FREE \$1.00 for every hour, Max. \$5.00
	THAT part of Water Street Lot #2 regulated by 24 Hour Permit Parking Monday to Sunday	AS PER THE CITY'S RATE REVIEW
	THAT part of Water Street Lot #2 regulated by Disabled Parking Monday to Saturday 7:00 a.m. to 9:00 p.m.	Pay and Display Fees
Westminster Drive Lot	THAT part of Westminster Drive Lot regulated by a Pay and Display Operation <ul style="list-style-type: none"> - a 2 hour maximum time limit - over a 2 hour maximum time limit Monday to Saturday 7:00 a.m. to 9:00 p.m.	FREE \$1.00 for every hour, Max. \$5.00
	THAT part of Westminster Drive Lot regulated by 24 Hour Permit Parking Monday to Sunday	AS PER THE CITY'S RATE REVIEW

SCHEDULE 'D' TO BY-LAW NO.62
OF
THE CORPORATION OF THE CITY OF CAMBRIDGE

PROPERTY NOT MUNICIPAL PARKING LOTS

<u>VIOLATION</u>	<u>PENALTY</u>
Parked on private property	\$21.00
Parked on Municipal Property	\$21.00
Parked on Local Board Property	\$21.00

**SCHEDULE 'E' TO BY-LAW NO.62
OF
THE CORPORATION OF THE CITY OF CAMBRIDGE**

MUNICIPAL PARKING LOTS

<u>VIOLATION</u>	<u>PENALTY</u>
Parked over time limit	\$11.00
Parked failure to pay parking fee	\$21.00
Parked failure to clearly display voucher	\$21.00
Parked at expired meter	\$21.00
Parked in permit parking space	\$21.00
Parked in lot between 2:30am and 6:00am	\$21.00
Parked in Market Square Lot between 2:30am and 6:00am	\$21.00
Parked on aisle	\$21.00
Parked on roadway	\$21.00
Parked along access roadway	\$21.00
Parked not wholly in parking space	\$21.00
Parked for buying merchandise	\$21.00
Parked for selling merchandise	\$21.00
Parked for repairing vehicles	\$21.00
Parked blocking another vehicle	\$21.00
Parked exceeding permitted vehicle length	\$41.00
Parked exceeding permitted vehicle width	\$41.00
Parked in no parking zone	\$21.00
Parked in loading zone	\$21.00
Parked displaying illegal parking permit	\$21.00
Parked displaying expired parking permit	\$21.00
Parked displaying cancelled parking permit	\$21.00
Parked displaying altered parking permit	\$21.00